



PARTS MANUAL

02.ENGINE

01.ENGINE

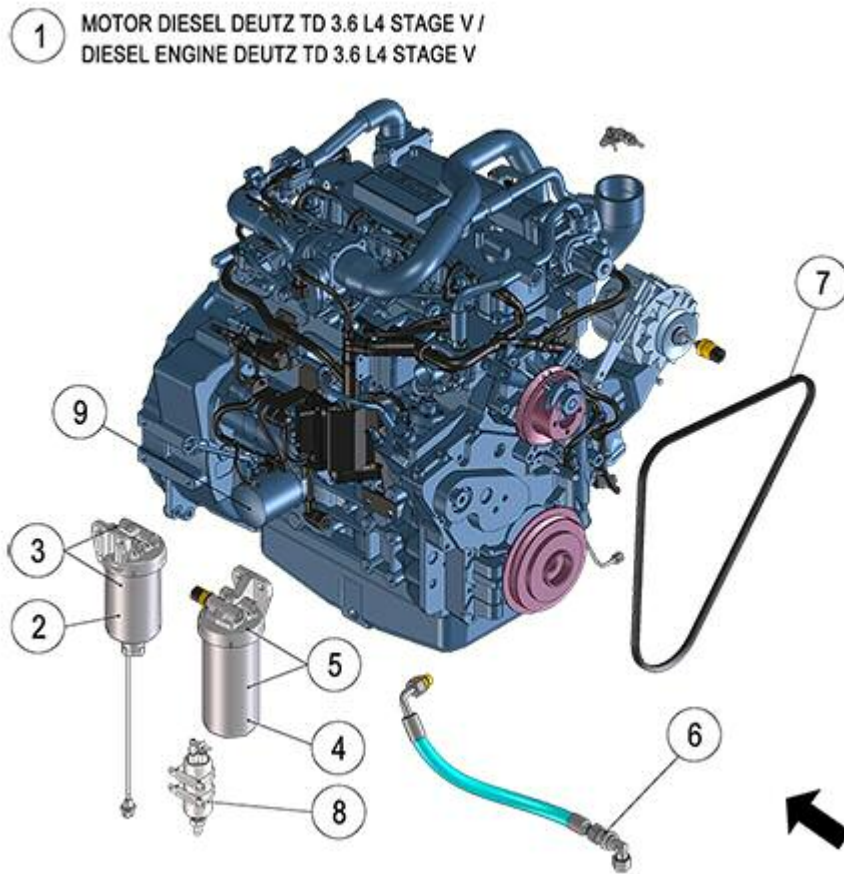

FIGURE	REFERENCE	DENOMINATION	AMOUNT
001	64.02033.00	EXHAUST PIPE C90 DEUTZ TD 3.6	1
001	66.02103.00	DEUTZ ENGINE TCD 3.6 L4 HT 55,4KW STAGE V	1
001	66.02103.00	DEUTZ ENGINE TCD 3.6 L4 HT 55,4KW STAGE V	1
002	DI04130241	FUEL FILTER	1
002	64.02035.00	EXHAUST MOTOR JOINT DEUTZ TD 3.6 L4	3
003	64.02034.00	EXHAUST CLAMP DEUTZ TD 3.6 L4	3
003	66.02015.00	FUEL PRE-FILTER	1
004	DI04131596	FUEL FILTER CARTRIDGE	1
004	64.02032.00	EXHAUST PIPE DEUTZ TD 3.6	1
005	948.01208.00	FLANGE	4
005	66.02013.00	FUEL FILTER	1
006	66.02017.00	PIPE SET	1
006	485.06012.00	SILICONE TUBE D6XD12	1
007	DI04123559	V-BELT	1
007	603.06035.86	SCREW DIN933 M6x35	1
008	64.02014.00	ELECTRIC FUEL PUMP DEUTZ	1

008	66.02016.00	FILTER DPF	1
009	66.02200.00	EXHAUST PIPE	1
009	DI01174416	SPIN-ON OIL FILTER	1
010	64.02031.00	SUPPORT DOC DEUTZ TD 3.6	2
011	603.08020.86	SCREW DIN933 M8x20	6
012	104.08000.00	WASHER DIN7980 D8	8
013	603.08025.86	SCREW DIN933 M8x25	2
014	101.08000.66	WASHER DIN125 D8	2
015	701.06000.66	NUT DIN934 M6X1	1
016	101.06000.66	WASHER DIN125 D6	7
017	830.02206.00	CLAMP LOOP	4
018	104.06000.00	WASHER DIN7980 D6	5
019	603.06030.86	SCREW DIN933 M6x30	4
020	64.02036.00	SKIP JOINT ESC. DEUTZ TD	1
021	931.05370.00	CLAMP TAPE 5x370	2

02.ENGINE

03.INTAKE SYSTEM



FIGURE	REFERENCE	DENOMINATION	AMOUNT
001	46.02038.00	ENGINE AIR FILTER	1
002	66.02304.00	Admission tube D70xD80	1
003	64.02324.00	TUBE D70x50x2	1
004	64.11042.00	INDICATOR FILTER AIR 50 mbar	1
005	46.02310.00	HOSE CLAMP FILTER	1
006	66.02303.01	SUPPORT	1
007	912.90110.66	HOSE CLAMP Ø90-110	2
008	912.60080.66	CLAMP	2
009	603.08030.86	SCREW DIN933 M8X30	2
010	101.08000.66	WASHER DIN125 D8	6
011	711.08000.66	NUT DIN982 M8	2
012	603.08035.86	SCREW DIN933	2
013	104.08000.00	WASHER DIN7980 D8	2
014	46.02312.00	SECURITY FILTER ELEMENT	1
015	46.02311.00	MAIN FILTER ELEMENT	1
016	66.02305.00	ADMISSION TUBE	1

02.ENGINE
04.MECHANICAL POWER

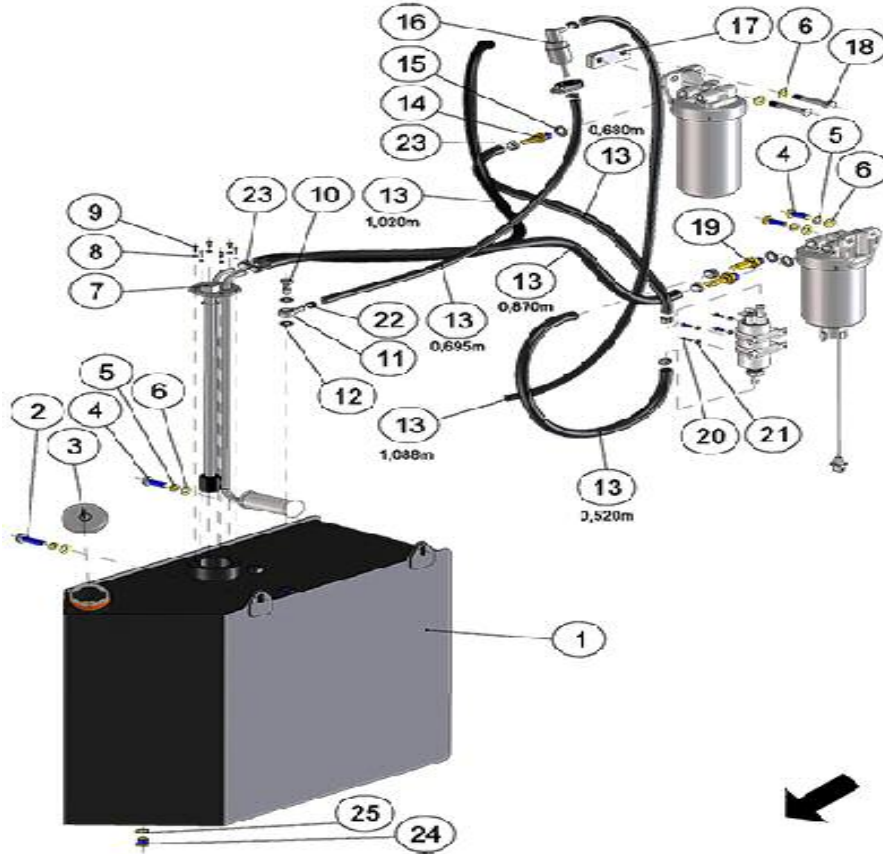

FIGURE	REFERENCE	DENOMINATION	AMOUNT
001	66.02040.00	TANK 69L GASOIL (9005)	1
002	603.10040.86	BOLT DIN933 M10x40	1
003	15.01524.01	CAP WITH LOCK 40X72	1
004	603.10030.86	SCREW DIN933	3
005	104.10000.00	WASHER DIN7980 D10	4
006	101.10000.66	WASHER DIN125 D10	6
007	30.02044.00	LEVEL 500MM DIESEL	1
008	104.04000.00	WASHER DIN7980 D4	6
009	601.04010.87	SCREW	6
010	28.00340.00	SIMPLE SCREW FITTING 1/4 Gx26	1
011	45.04106.00	NIPPLE O/TB	1
012	28.00341.00	METALLIC GASKET BUNA D1/4	2
013	469.01017.00	TUBE MAT.	1
014	64.10130.00	TANG FITTING M16x1.5-DN10	1
015	20.10505.00	BUNA METAL SEAL M16	3
016	45.01526.00	PREFILTER FUEL/HYDRAULIC	1

017	66.02401.00	SUPPORT GASOIL DEUTZ (7022)	1
018	604.10055.86	BOLT DIN931 M10x55	2

02.ENGINE**04.MECHANICAL POWER**

FIGURE	REFERENCE	DENOMINATION	AMOUNT
019	66.10130.00	FITTING M16x1.5 -DN13	2
020	603.05015.86	SCREW DIN933	4
021	104.05000.00	WASHER DIN7980 D5	4
022	948.01408.00	CLAMP Ø14	3
023	948.01708.00	FLANGE D17	7
024	10.00921.00	CAP M14X150 DIN908	1
025	107.14000.10	WASHER AL 14x20x1.5	1

02.ENGINE
05.COOLING SYSTEM

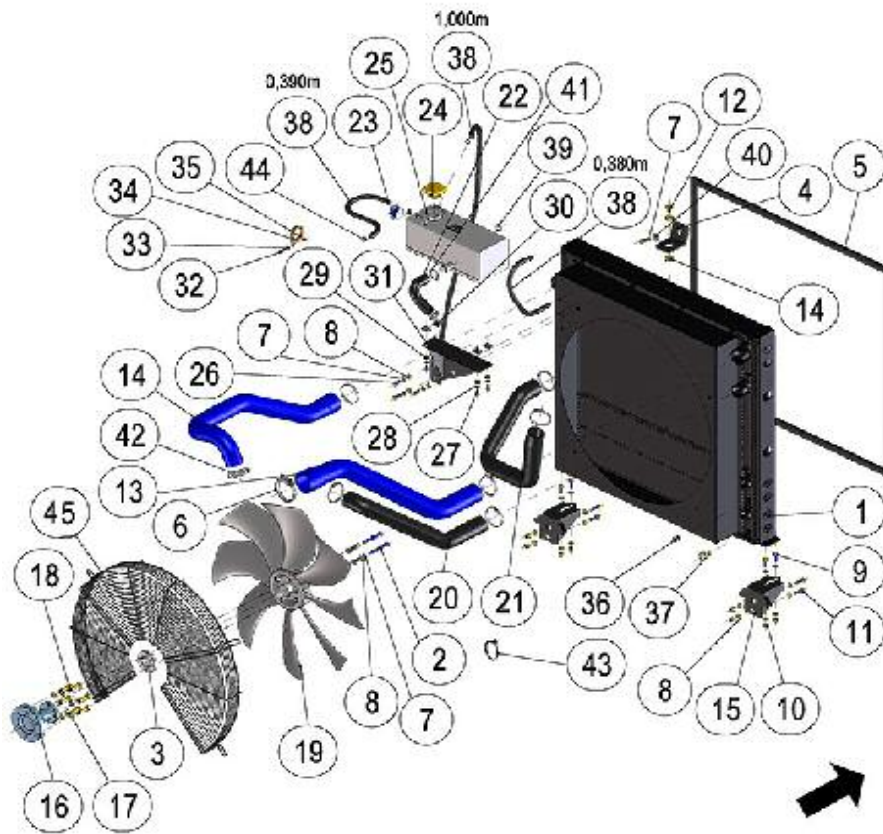

FIGURE	REFERENCE	DENOMINATION	AMOUNT
001	66.02502.00	RADIATOR	1
002	603.08040.86	SCREW DIN933	4
003	472.02015.00	RUBBER PROFILE MAT.	1
004	472.00410.00	RUBBER PROFILE 22X22	1
005	477.10020.00	RUBBER PROFILE MAT.	1
006	912.60080.66	CLAMP	1
007	104.08000.00	WASHER DIN7980 D8	11
008	101.08000.66	WASHER DIN125 D8	25
009	603.08025.86	SCREW DIN933 M8x25	8
010	711.08000.66	NUT DIN982 M8	8
011	603.08030.86	SCREW DIN933 M8X30	4
012	603.10015.86	SCREW DIN933	1
013	66.02520.00		1
014	66.02521.00		1
015	66.02504.00	SUPPORT FIXATION RADIATOR 10TN	2
016	66.02503.00	FAN SUPPORT	1

017	104.10000.00	WASHER DIN7980 D10	6
018	604.10045.86	SCREW DIN931	6

02.ENGINE

05.COOLING SYSTEM

FIGURE	REFERENCE	DENOMINATION	AMOUNT
019	66.02512.00		1
020	66.02522.00	TUBE ENG. RAD. D52/42	1
021	66.02523.00	TUBE RAD. ENG. D52/42	1
022	66.02525.00	RUBBER TUBE D22	1
023	30.10041.00	LEVEL VISUAL INDICATOR 1	1
024	32.02151.00	REFRIGERANT CAP 1BAR	1
025	66.02530.00	EXPANSION TANK	1
026	603.08020.86	SCREW DIN933 M8x20	3
027	603.06015.86	SCREW DIN933 M6x15	4
028	104.06000.00	WASHER DIN7980 D6	4
029	112.06000.66	WASHER DIN9021 D6	4
030	727.06004.86	CAGED NUT M6x4	4
031	66.02506.00	SUPPORT FIXATION EXPANSION VESSEL	1
032	603.06020.86	SCREW DIN933 M6x20	1
033	101.06000.66	WASHER DIN125 D6	1
034	830.04006.00	CLAMP LOOP D40x6	1
035	711.06000.66	NUT DIN982 M6	1
036	66.10710.00	STOPPER M12X150 HEXAGON	1
037	48.11015.00	TEMPERATURE SENSOR (HYDRAULIC OIL)	1
038	469.03014.00	HOSE L/P MAT. 8x14	1
039	107.14000.10	WASHER AL 14x20x1.5	1
040	112.08000.66	WASHER DIN9021 D8	2
041	912.20032.00	CLAMP	2
042	912.40060.66	CLAMP D40-60	4
043	931.05370.00	CLAMP TAPE 5x370	1
044	948.01308.00	SPRING CLAMP Ø13	5
045	66.02515.00	GRILLE RADIATOR	1

02.ENGINE

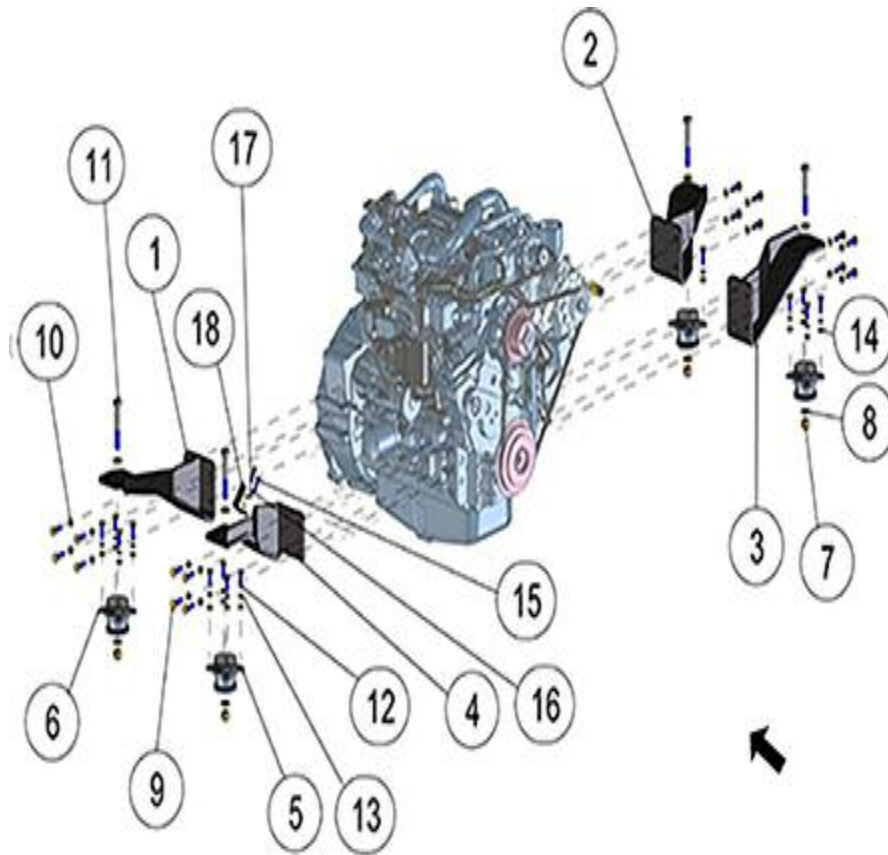

FIGURE	REFERENCE	DENOMINATION	AMOUNT
001	66.02603.00	FRONT LEFT ENGINE SUPPORT	1
002	66.02602.00	RIGHT FRONT MOTOR SUPPORT	1
003	66.02601.00	REAR ENGINE REAR SUPPORT	1
004	66.02600.00	LEFT REAR ENGINE SUPPORT	1
005	66.02604.00	SHOCK ABSORBER	2
006	66.02605.00	SHOCK ABSORBER	2
007	711.16000.66	NUT DIN982 M16 8.8 K	4
008	101.16000.66	WASHER DIN125 D16	8
009	603.12035.86	SCREW DIN933	16
010	104.12000.00	WASHER DIN7980 D12	16
011	604.16110.86	SCREW DIN931 M16x110	4
012	603.10035.86	SCREW DIN933 M10x35	16
013	104.10000.00	WASHER DIN7980 D10	16
014	101.10000.66	WASHER DIN125 D10	16
015	603.08030.86	SCREW DIN933 M8X30	2
016	104.08000.00	WASHER DIN7980 D8	2



017	101.08000.66	WASHER DIN125 D8	2
018	66.02607.00	SUPPORT	1

03. TRANSMISSION

HYDROSTATIC TRANSMISSION

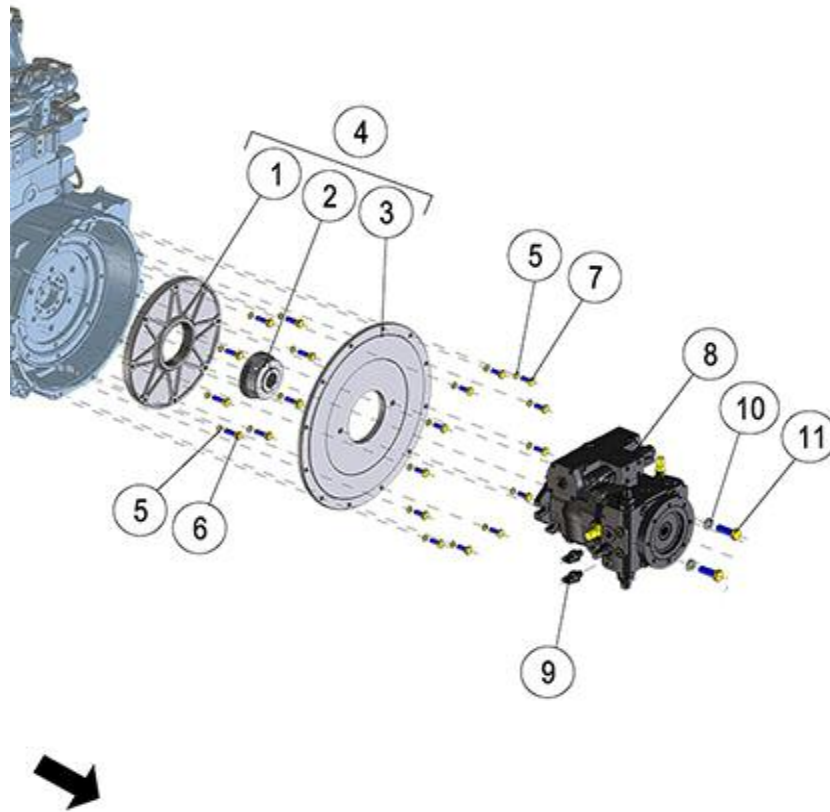

FIGURE	REFERENCE	DENOMINATION	AMOUNT
001	66.03271.00	ACOP CIL/DEN DEUTZ	1
002	66.03272.00	ACOP. DEN/DEN	1
003	66.03273.00	ACOP CIL/CIL	1
004	66.03270.00	CONJ ACOP. A4VG71 TCD3.6	1
005	104.10000.00	WASHER DIN7980 D10	20
006	603.10035.86	SCREW DIN933 M10x35	8
007	603.10025.86	SCREW DIN933 M10x25	12
008	66.03250.00	HYDRAULIC PUMP 71CC	1
009	66.11122.00	SENSOR PRESSURE BRR PR4	2
010	65.03217.00	WASHER 16x7x26	2
011	603.16045.97	SCREW DIN933	2

03. TRANSMISSION

HYDROSTATIC ENGINE

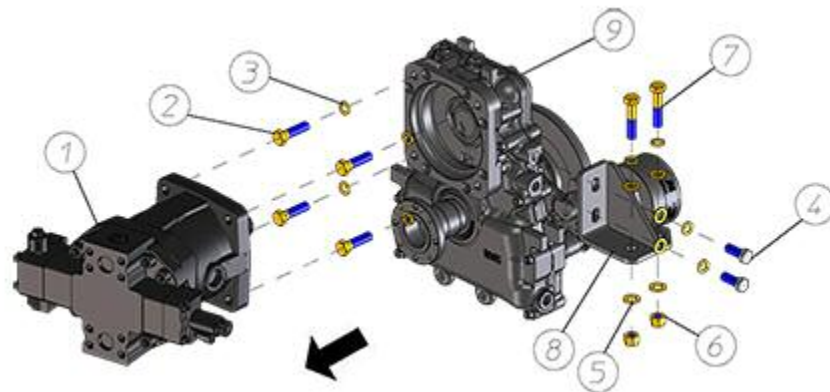

FIGURE	REFERENCE	DENOMINATION	AMOUNT
001	66.03261.00	160CC HYDRAULIC MOTOR	1
002	604.16060.86	SCREW DIN931	4
003	104.16000.00	CIR-CLIP EXT. DIN7980	8
004	603.16040.86	SHOCK ABSORBER, 35x50x72	2
005	101.16000.66	WASHER DIN125 D16	6
006	711.16000.86	NUT DIN982 M16 C8	2
007	604.16070.86	BOLT DIN931 M16x70	2
008	66.04431.00	SUPPORT FIXING REDUCTION BOX	1
009	66.03241.00	GEARBOX	1

03. TRANSMISSION FRONT AXLE (1)

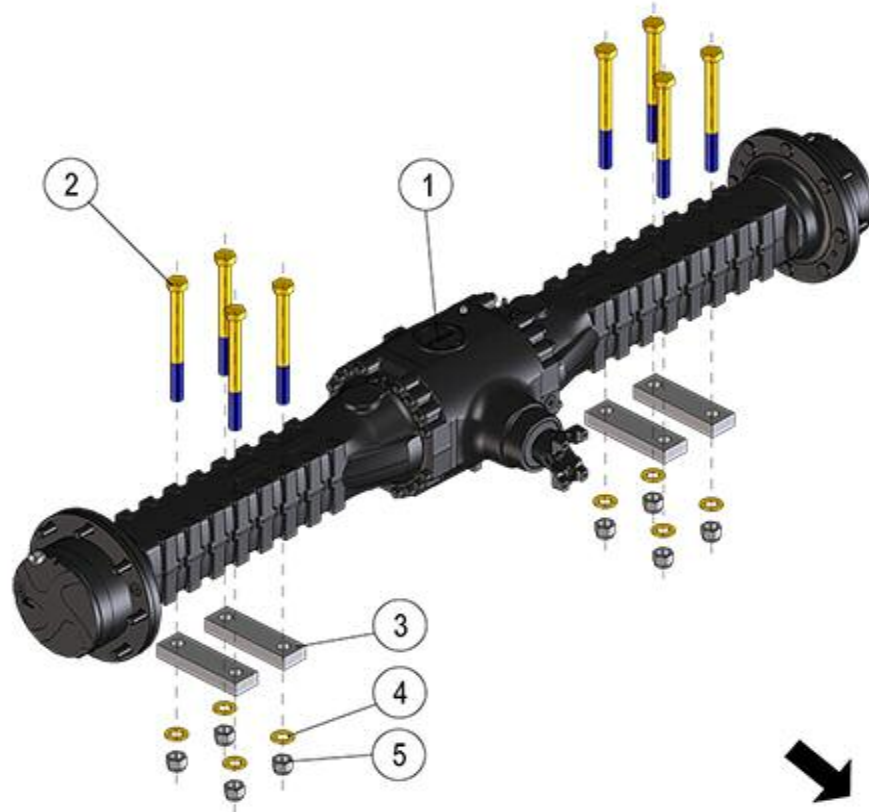

FIGURE	REFERENCE	DENOMINATION	AMOUNT
001	66.03300.00	FIXED FRONT AXLE	1
002	604.24260.86	SCREW DIN931	8
003	64.04139.00	Deck 30X60X205	4
004	101.24000.66	WASHER DIN125	8
005	711.24000.66	NUT DIN982 M24X3	8

03. TRANSMISSION FRONT AXLE (2)

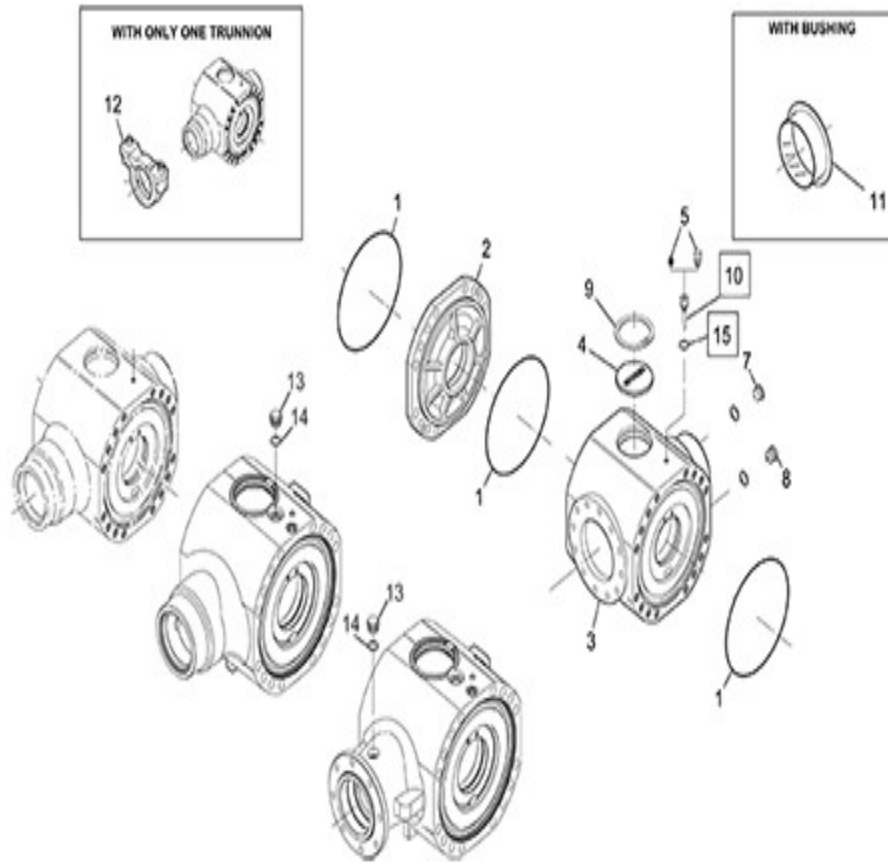

FIGURE	REFERENCE	DENOMINATION	AMOUNT
001	DA001051178	O-RING	3
002	DA1120100706	COVER	1
003	DA1120103703	CASING	1
004	DA1710101504	CAP	1
005	DA1120101806	CAP	1
007	DA1120161001	CAP	7
008	DA1120161003	MAGNET PLUG	1
009	DA002020088	CIRCLIP	1

03. TRANSMISSION

FRONT AXLE (3)

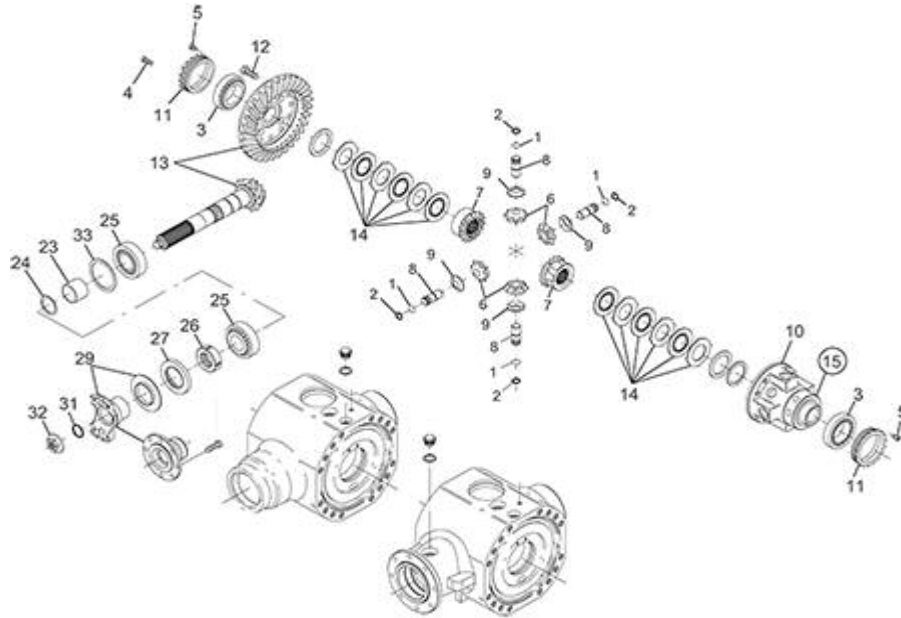

FIGURE	REFERENCE	DENOMINATION	AMOUNT
001	DA002063163	CIRCLIP	4
002	DA002143244	CIRCLIP	4
003	DA7250401102	BUSH	2
004	DA016040417	BOLT	4
005	DA016304162	BOLT	2
006	DA1120400401	DIFFERENTIAL PINION	4
007	DA1120400508	DIFFERENTIAL SIDE GEAR	2
008	DA1120470602	BOLT	4
009	DA1120400801	WASHER	4
010	DA1120401104	DIFFERENTIAL HOUSING	1
011	DA1120401602	CLAMP	2
012	DA016283390	SCREW	12
013	DA1120451004	BEVEL GEAR SET	1
014	DA1120461103	DIFFERENTIAL DISC SET	2
015	DA1120470308	LIMITED-SLIP DIFERENTIAL	1
023	DA1120400902	SPACER	1

023	DA1120400902	SPACER	1
024	DA1230440002	SHIM SET	1

03. TRANSMISSION FRONT AXLE (3)

FIGURE	REFERENCE	DENOMINATION	AMOUNT
025	DA005100162	BUSH	2
026	DA9530401201	CLAMP	1
027	DA001033221	SEAL	1
029	DA1120473101	FLANGE	1
031	DA001053158	O-RING	1
032	DA3571413902	NUT	1
033	DA1120440004	SHIM SET	1

03. TRANSMISSION FRONT AXLE (4)

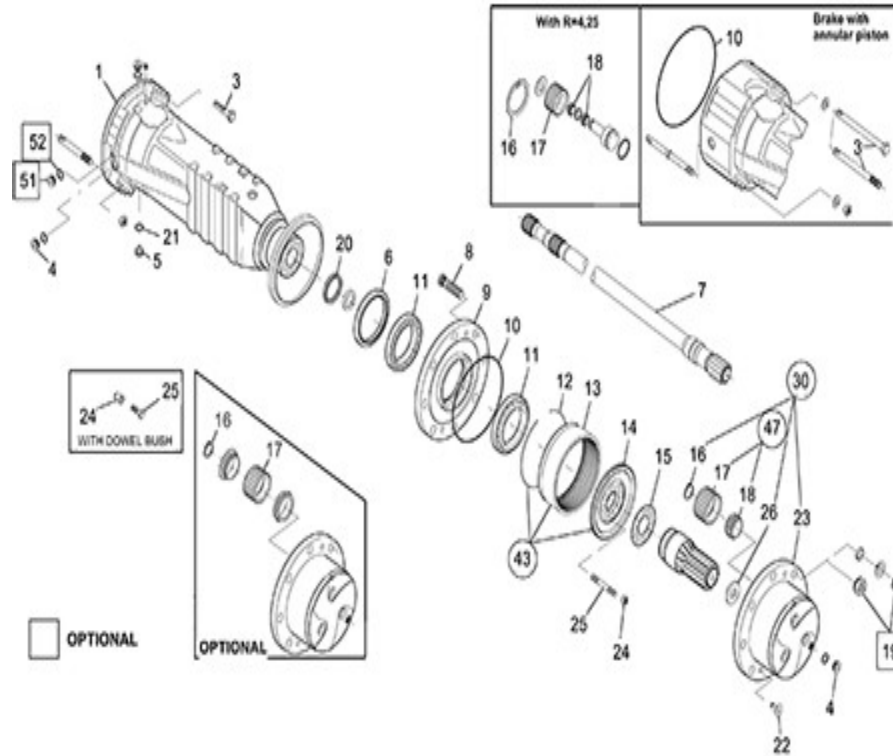

FIGURE	REFERENCE	DENOMINATION	AMOUNT
001	DA1120601827	ARM	2
003	DA1120607001	SCREW	28
004	DA1120161001	CAP	4
005	DA1120161003	MAGNET PLUG	2
006	DA1770600901	SEAL	2
007	DA1120600201	HALF SHAFT	2
008	DA7020601702	STUD	16
009	DA1120611003	WHEEL HUB	2
010	DA001051178	O-RING	2
011	DA005103166	BUSH	4
012	DA002063193	CIRCLIP	2
013	DA1120600504	CROWN GEAR	2
014	DA1120600707	SUPPORT	2
015	DA1120602601	LOCK PLATE	2
016	DA002143191	CIRCLIP	4
017	DA1120600606	PLANETARY GEAR	8

018	DA7300602604	BUSH	8
019	DA006080206	WHEEL NUT	16

03. TRANSMISSION FRONT AXLE (4)

FIGURE	REFERENCE	DENOMINATION	AMOUNT
020	DA001404360	SEAL	2
022	DA016060442	SCREW	4
023	DA1120605005	PLANET CARRIER COVER	1
024	DA006224380	NUT	16
025	DA1120602503	STUD	16
026	DA1120601702	WASHER	1
030	DA2120671018	PLANET CARRIER COVER	2
043	DA2120670707	CROWN GEAR SUPPORT KIT	2
047	DA1120670606	PLANETARY GEAR SET	8
051	DA1370600602	CAP	2
052	DA011070918	WASHER	2

03. TRANSMISSION

REAR AXLE (1)

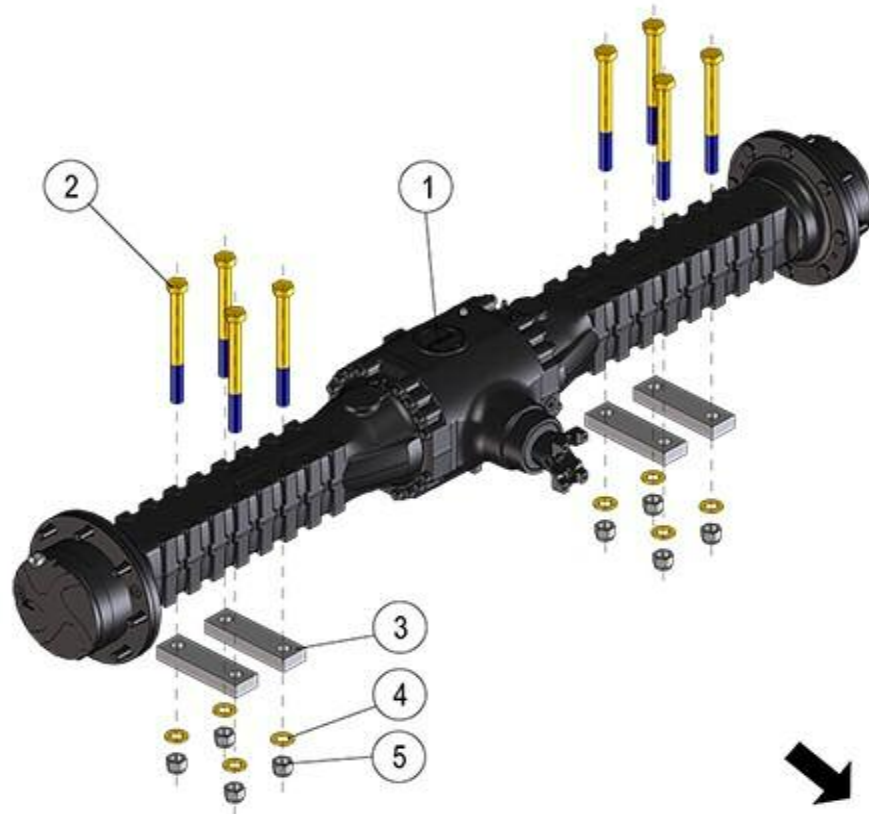

FIGURE	REFERENCE	DENOMINATION	AMOUNT
001	66.03301.00	REAR AXLE	1
002	604.24260.86	SCREW DIN931	8
003	64.04139.00	Deck 30X60X205	4
004	101.24000.66	WASHER DIN125	8
005	711.24000.66	NUT DIN982 M24X3	8

03. TRANSMISSION

REAR AXLE (2)

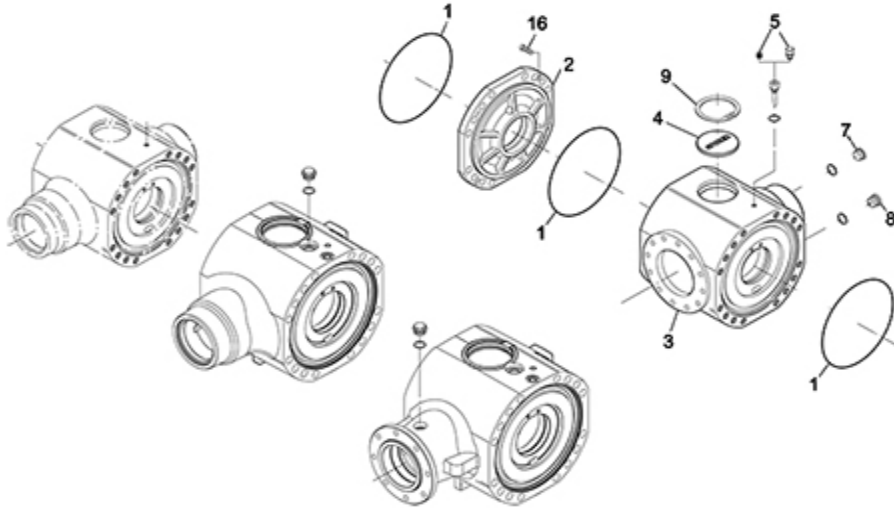

FIGURE	REFERENCE	DENOMINATION	AMOUNT
001	DA001051178	O-RING	3
002	DA1120100706	COVER	1
003	DA1120103703	CASING	1
004	DA1710101504	CAP	1
005	DA1120101806	CAP	1
007	DA1120161001	CAP	1
008	DA1120161003	MAGNET PLUG	1
009	DA002020088	CIRCLIP	1
016	DA016040417	BOLT	4

03. TRANSMISSION

REAR AXLE (3)

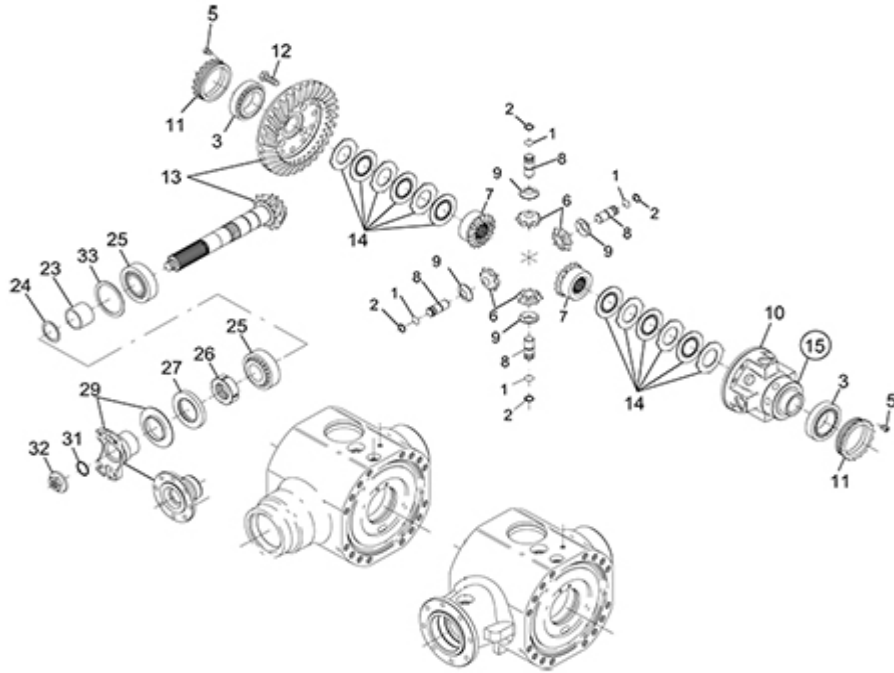

FIGURE	REFERENCE	DENOMINATION	AMOUNT
001	DA002063163	CIRCLIP	4
002	DA002143244	CIRCLIP	4
003	DA7250401102	BUSH	2
005	DA016304162	BOLT	2
006	DA1120400401	DIFFERENTIAL PINION	4
007	DA1120400508	DIFFERENTIAL SIDE GEAR	2
008	DA1120470602	BOLT	4
009	DA1120400801	WASHER	4
010	DA1120401104	DIFFERENTIAL HOUSING	1
011	DA1120401602	CLAMP	2
012	DA016283390	SCREW	12
013	DA1120450064	CONICAL GEAR SET	1
014	DA1120461103	DIFFERENTIAL DISC SET	2
015	DA1120470308	LIMITED-SLIP DIFERENTIAL	1
023	DA1120400902	SPACER	1
024	DA1230440002	SHIM SET	1

025	DA005100162	BUSH	2
026	DA9530401201	CLAMP	1

03. TRANSMISSION

REAR AXLE (3)

FIGURE	REFERENCE	DENOMINATION	AMOUNT
027	DA001033221	SEAL	1
029	DA1120473101	FLANGE	1
031	DA001053158	O-RING	1
032	DA3571413902	NUT	1
033	DA1120440004	SHIM SET	1

03. TRANSMISSION REAR AXLE (4)

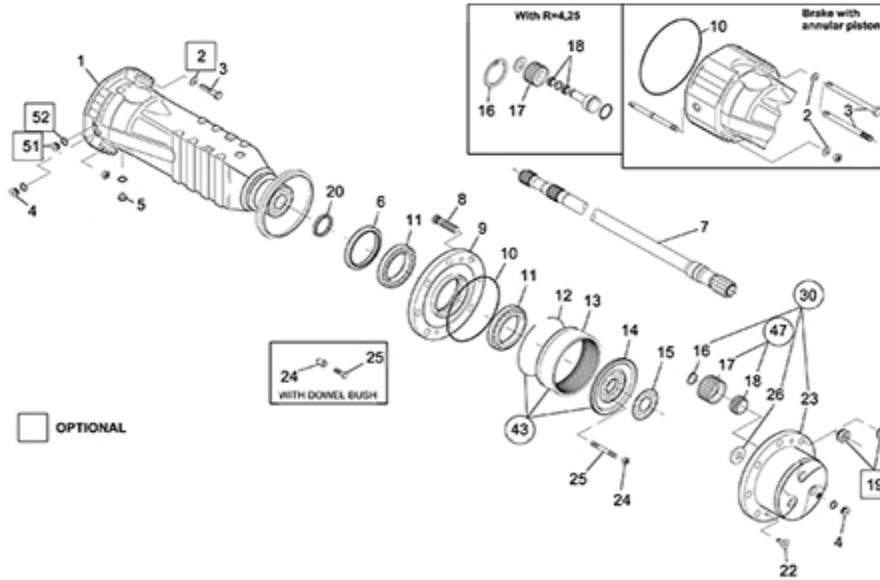

FIGURE	REFERENCE	DENOMINATION	AMOUNT
001	DA1120601827	ARM	2
003	DA1120607001	SCREW	28
004	DA1120161001	CAP	4
005	DA1120161003	MAGNET PLUG	2
006	DA1770600901	SEAL	2
007	DA1120600201	HALF SHAFT	2
008	DA7020601702	STUD	16
009	DA1120611003	WHEEL HUB	2
010	DA001051178	O-RING	2
011	DA005103166	BUSH	4
012	DA002063193	CIRCLIP	2
013	DA1120600504	CROWN GEAR	2
014	DA1120600707	SUPPORT	2
015	DA1120602601	LOCK PLATE	2
016	DA002143191	CIRCLIP	8
017	DA1120600606	PLANETARY GEAR	8

018	DA7300602604	BUSH	8
019	DA006080206	WHEEL NUT	16

03. TRANSMISSION REAR AXLE (4)

FIGURE	REFERENCE	DENOMINATION	AMOUNT
020	DA001404360	SEAL	2
022	DA016060442	SCREW	4
023	DA1120605005	PLANET CARRIER COVER	1
024	DA006224380	NUT	16
025	DA1120602503	STUD	16
026	DA1120601702	WASHER	1
030	DA2120671018	PLANET CARRIER COVER	2
043	DA2120670707	CROWN GEAR SUPPORT KIT	2
047	DA1120670606	PLANETARY GEAR SET	8
051	DA1370600602	CAP	2
052	DA011070918	WASHER	2

03. TRANSMISSION

REAR AXLE (5)

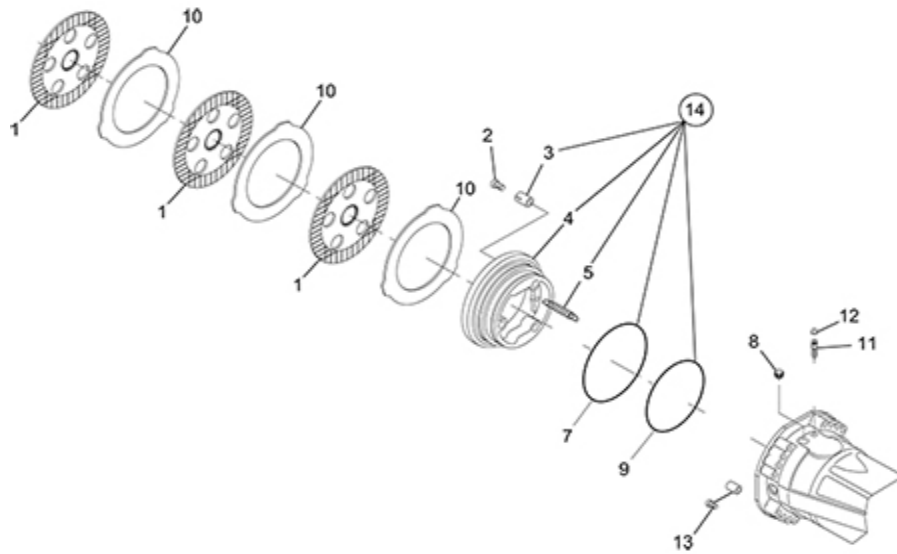

FIGURE	REFERENCE	DENOMINATION	AMOUNT
001	DA1120761004	DISC	8
002	DA1120703709	SCREW	6
003	DA1120700204	SPRING	6
004	DA1120700716	PISTON	2
005	DA1800700401	SPRING	6
007	DA1120707601	O-RING	2
008	DA1120761501	CAP	2
009	DA1120707501	O-RING	2
010	DA1120700606	INTERMEDIATE BRAKE DISC	10
011	DA7340701401	BOLT	2
012	DA7340701501	CAP	2
013	DA1620700405	SCREW	2
014	DA1120770416	PISTON SET	2

03. TRANSMISSION

CARDAN JOINT

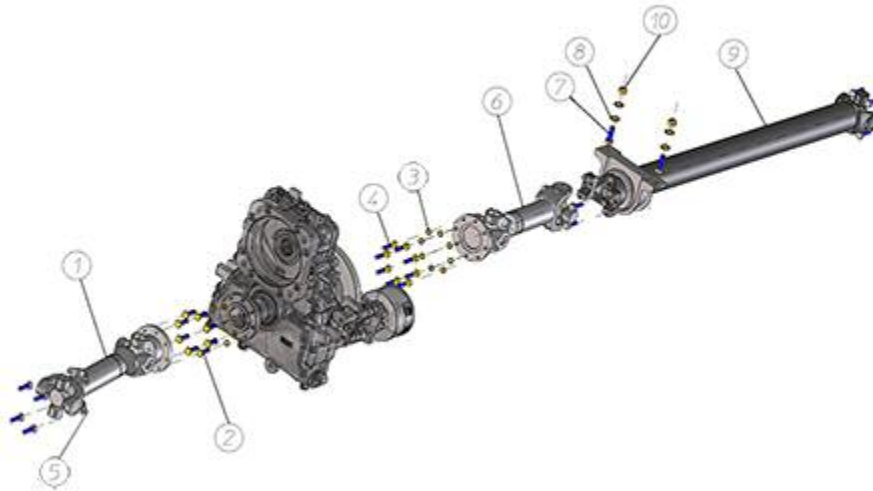

FIGURE	REFERENCE	DENOMINATION	AMOUNT
001	66.03601.00	CARDAN 310	1
002	603.10030.86	SCREW DIN933	8
003	104.10000.00	WASHER DIN7980 D10	16
004	604.10040.86	SCREW DIN931	8
005	63.03123.00	KIT CABLE TIE WITH SCREWS DANA	1
006	66.03602.00	CARDAN 255	1
007	603.12040.86	SCREW DIN933 M12x40	2
008	101.12000.66	WASHER DIN125 D12	4
009	66.03610.00	UNIVERSAL JOINT	1
010	711.12000.66	NUT DIN982 M12	2

04. CHASSIS

CHASSIS (PART 1)

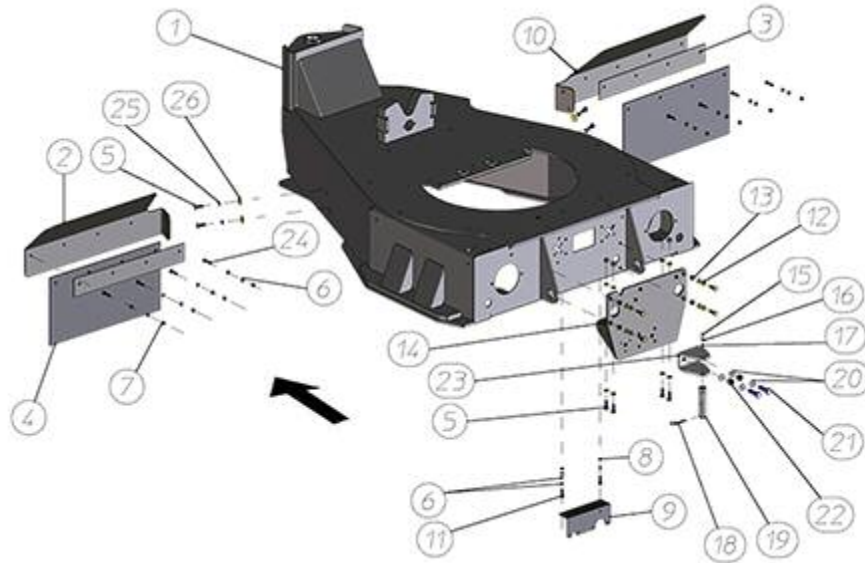

FIGURE	REFERENCE	DENOMINATION	AMOUNT
001	66.04201.00	ROTATION CHASSIS	1
002	66.04120.00	SHEET	1
003	66.04123.00	SHEET	2
004	66.04124.00	CARPET	2
005	603.10030.86	SCREW DIN933	12
006	101.08000.66	WASHER DIN125 D8	19
007	711.08000.66	NUT DIN982 M8	8
008	104.08000.00	WASHER DIN7980 D8	3
009	66.04210.02	FIXING SUPPORT	1
010	66.04121.00	SHEET	1
011	603.08030.86	SCREW DIN933 M8X30	2
012	101.10000.66	WASHER DIN125 D10	16
013	711.10000.66	SHOCK ABSORBER	8
014	66.04136.00	SHEET	1
015	603.05010.86	SCREW DIN933 M5x10	1
016	15.00834.00	CHAIN	1
017	701.05000.66	NUT DIN934 M5x0.8	1
018	15.00836.00	PIN DIN11024 R4	1
019	15.00835.00	AXLE CPA/GRA 25x30x135	1
020	101.14000.66	WASHER DIN125 D14	4
021	604.14050.86	SCREW DIN931	2
022	711.14000.66	NUT DIN982 M14 8.8 K	2



023	70.08090.00	support 80X100X125	1
024	603.08035.86	SCREW DIN933	8
025	104.10000.00	WASHER DIN7980 D10	4
026	112.10000.66	WASHER DIN9021 D10	4

04. CHASSIS

CHASSIS (PART 2)

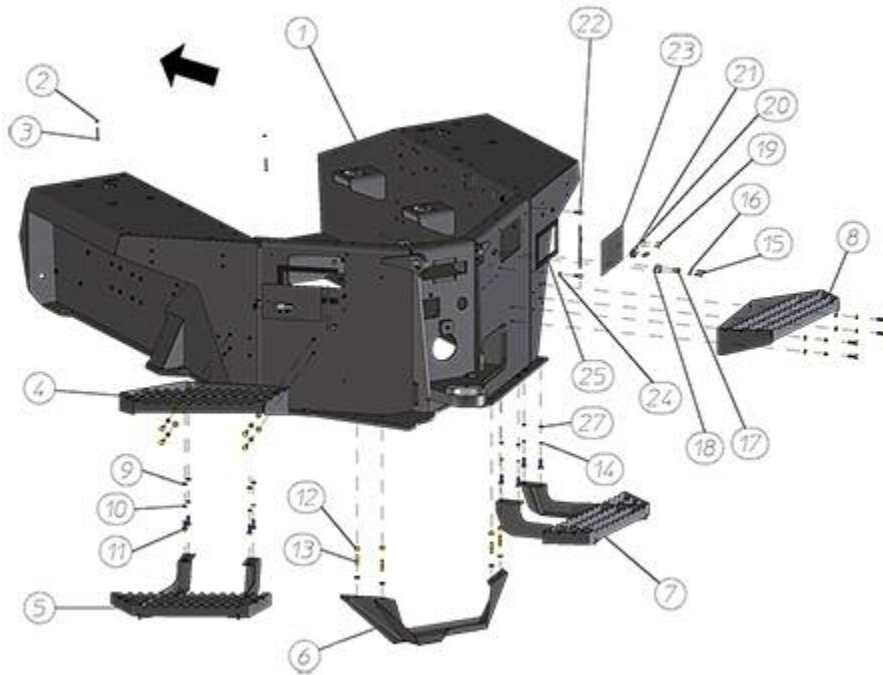

FIGURE	REFERENCE	DENOMINATION	AMOUNT
001	66.04400.01	CHASSIS	1
002	701.06000.66	NUT DIN934 M6X1	2
003	603.06045.86	SCREW DIN933	2
004	66.04133.02	RIGHT UPPER STEP	1
005	66.04131.02	RIGHT LOWER STEP	1
006	66.04410.01	PROTECTION	1
007	66.04130.02	LEFT LOWER STEP	1
008	66.04132.02	LEFT UPPER STEP	1
009	101.10000.66	WASHER DIN125 D10	8
010	104.10000.00	WASHER DIN7980 D10	6
011	603.10030.86	SCREW DIN933	8
012	711.10000.66	SHOCK ABSORBER	2
013	15.01034.00	STUD DIN938* 41 M10x1,5	2
014	104.08000.00	WASHER DIN7980 D8	2
015	603.06025.86	SCREW DIN933 M6x25	2
016	104.06000.00	WASHER DIN7980 D6	2
017	43.50129.00	CAP	1
018	64.10187.00		1
019	502.05016.60	RIVET DIN1476	8

020	60.01924.01	LATCH	2
021	60.01925.01	LATCH	1
022	66.04735.00	SUPPORT ARTICULATION M8X1.25X20	4
023	66.04420.00	TANK COVER	2
024	711.08000.66	NUT DIN982 M8	4
025	477.10020.00	RUBBER PROFILE MAT.	2

04. CHASSIS

CHASSIS AXLE

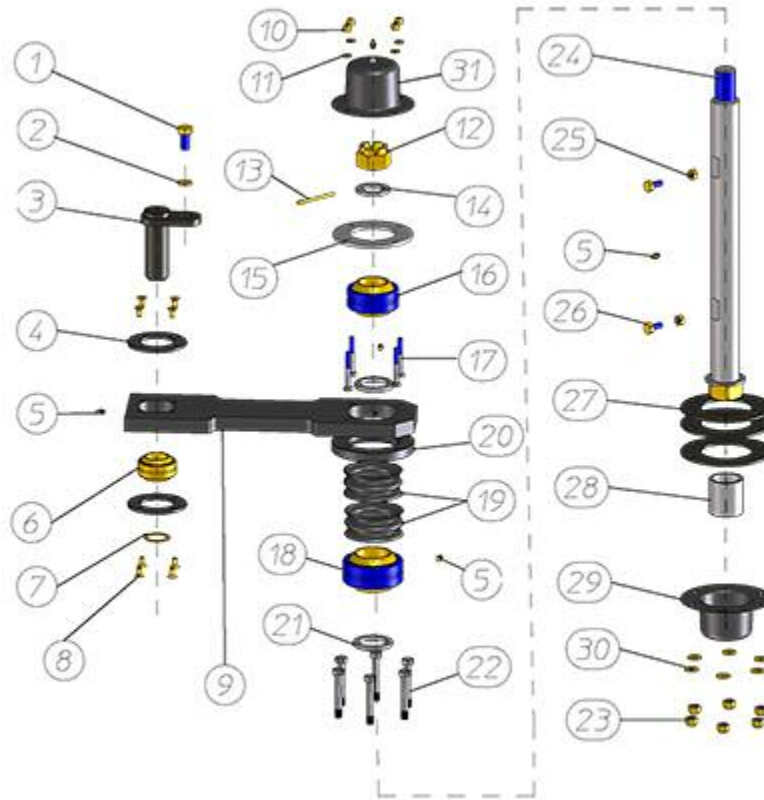

FIGURE	REFERENCE	DENOMINATION	AMOUNT
001	603.16030.86	BOLT DIN933 M16x30	1
002	104.16000.00	CIR-CLIP EXT. DIN7980	1
003	64.06224.00	SPINDLE 40x120	1
004	64.06219.00	COVER 6x104	2
005	901.08000.33	GREASER DIN71412-A M8x1,25	5
006	941.40040.01	BUSHING GE40FO 2RS-C2	1
007	904.40000.00	RING DIN471	1
008	618.08016.86	FLAT HEAD SOCKET CAP SCREW DIN7991 M8x16	8
009	64.06212.01	CONNECTING ROD 90X68X504.5	1
010	711.08000.66	NUT DIN982 M8	4
011	101.08000.66	WASHER DIN125 D8	4
012	703.36000.60	NUT DIN935 M36x4	1
013	401.06070.60	PIN DIN94 6x70	1
014	64.06221.00	RING 37x60x6	1
015	65.04143.00	COVER 140x6	1

016	941.50056.01	BUSHING GE50FO 2RS-2C	1
017	604.08065.86	SCREW DIN931 M8X65	4
018	941.60063.01	BUSHING GE60FO 2RS-2C	1
019	64.06214.00	DUST EXCLUDER 43x103	2
020	64.06213.00	COVER	1
021	64.06215.00	RING 8x51x70	2
022	604.12080.86	SCREW DIN931 M12x80	6
023	711.12000.86	NUT DIN982 M12 C8	6
024	63.04144.01	SHAFT 36X36X606	1
025	701.10000.66	NUT DIN934 M10x1.5	2
026	603.10025.86	SCREW DIN933 M10x25	2
027	64.06226.00	COVER 90X160X4	3
028	64.06217.00	BUSHING 50x60x5	1
029	64.06218.01	COVER 73/160	1
030	101.12000.66	WASHER DIN125 D12	6
031	64.06210.02	COVER Ø93X145	1

04. CHASSIS SUPPORTS

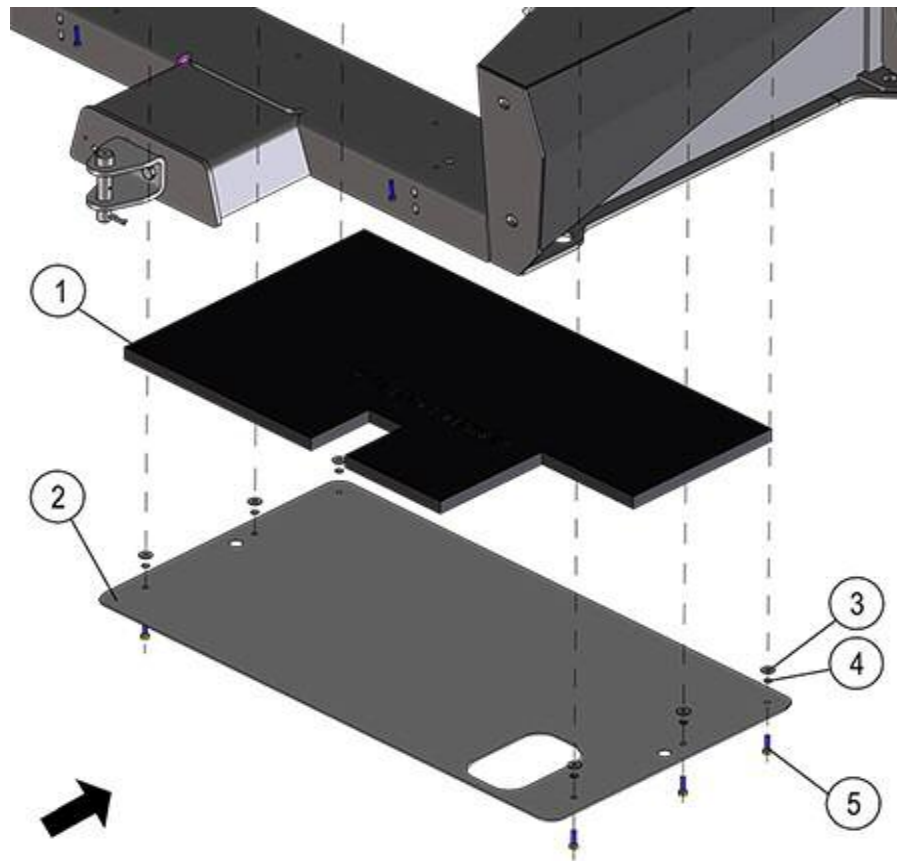

FIGURE	REFERENCE	DENOMINATION	AMOUNT
001	66.04040.00	ACOUSTIC ABSORBENT	1
002	66.04020.00	ENGINE PROTECTOR AND SOUNDLESS COVER	1
003	112.08000.66	WASHER DIN9021 D8	6
004	104.08000.00	WASHER DIN7980 D8	6
005	603.08030.86	SCREW DIN933 M8X30	6

05. BRAKING SYSTEM

01.FOOT BRAKE

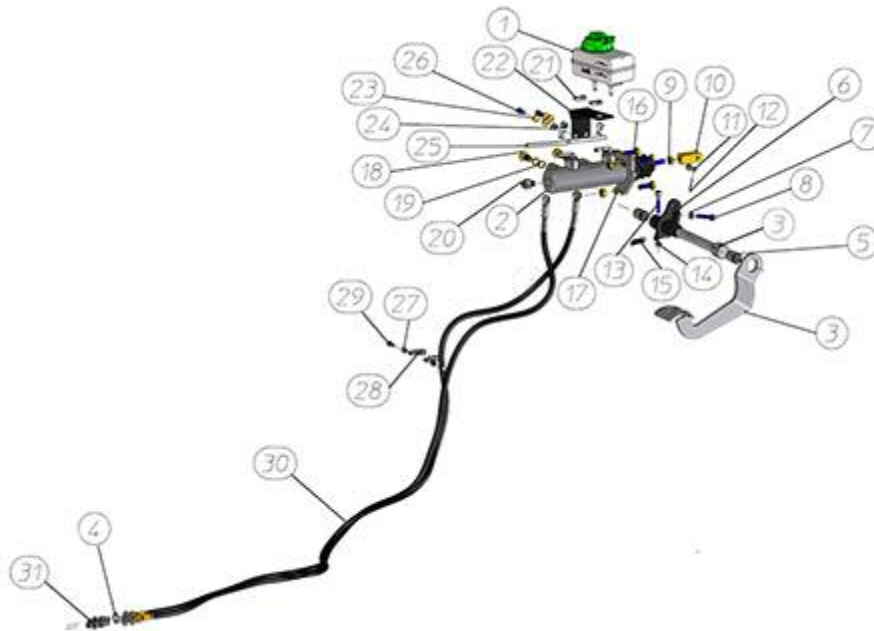

FIGURE	REFERENCE	DENOMINATION	AMOUNT
001	65.05150.00		1
002	64.05112.00	MASTER CYLINDER	1
003	66.13212.00	BRAKE LEVER	1
004	101.12000.66	WASHER DIN125 D12	4
005	952.02030.00	BUSH	2
006	66.13213.00	TUBE	16
007	701.08000.66	NUT DIN934 M8X1,25	1
008	603.08040.86	SCREW DIN933	1
009	701.10000.66	NUT DIN934 M10x1.5	4
010	20.05040.00	ART. FORK	1
011	01.00514.01	AXLE CIL/CPA 14x8x28	1
012	401.02025.60	PIN DIN94 2x25	1
013	601.08040.96	HEXAGON SOCKET HEAD SCREW DIN912 M8x40	1
014	720.08000.66	NUT DIN985 M8 AUTOLOCKING	1
015	01.00139.00	SPRING TENSION	1
016	603.10030.86	SCREW DIN933	3
017	104.10000.00	WASHER DIN7980 D10	3
018	55.00760.00	NIPPLE SCREW SIM.	2
019	106.12000.20	WASHER CU	4
020	43.01520.00	BRAKE FLUID SWITCH	1
021	948.01107.00	CLAMP SPRING	4

022	66.05108.00	SHEET	1
023	101.08000.66	WASHER DIN125 D8	4
024	711.08000.66	NUT DIN982 M8	2
025	469.15009.00	PLASTIC HOSE 6X9	2
026	630.08020.96	SCREW ISO7380	2
027	711.06000.66	NUT DIN982 M6	2
028	830.01406.00	CLAMP LOOP	2
029	603.06015.86	SCREW DIN933 M6x15	2
030	66.05021.00	TUBE	2
031	64.05123.00	FITTING M/M	2

05. ACTUATORS

BRAKES

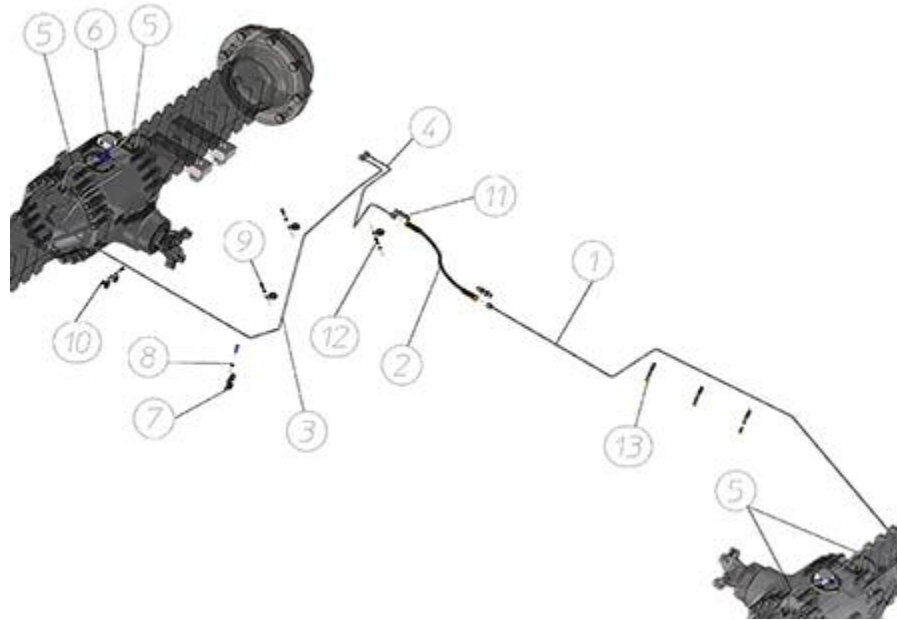

FIGURE	REFERENCE	DENOMINATION	AMOUNT
001	66.05022.00	METAL PIPE	1
002	66.05119.00	TUBE	1
003	66.05015.00	TUBE BUNDY4 953X631X332	1
004	66.05014.00	TUBE BUNDY4 183X161X158	1
005	64.05128.00	HYDRAULIC STEEL PIPE, BUNDY 4 200X100	4
006	64.05129.00	RACOR H/H/H M12/M12/M12	2
007	830.01006.00	CLAMP LOOP D10x6	10
008	104.06000.00	WASHER DIN7980 D6	8
009	601.06020.86	SCREW DIN912	3
010	603.06015.86	SCREW DIN933 M6x15	2
011	64.05123.00	FITTING M/M	2
012	603.06025.86	SCREW DIN933 M6x25	2
013	603.06020.86	SCREW DIN933 M6x20	3

05. ACTUATORS

ACCELERATOR

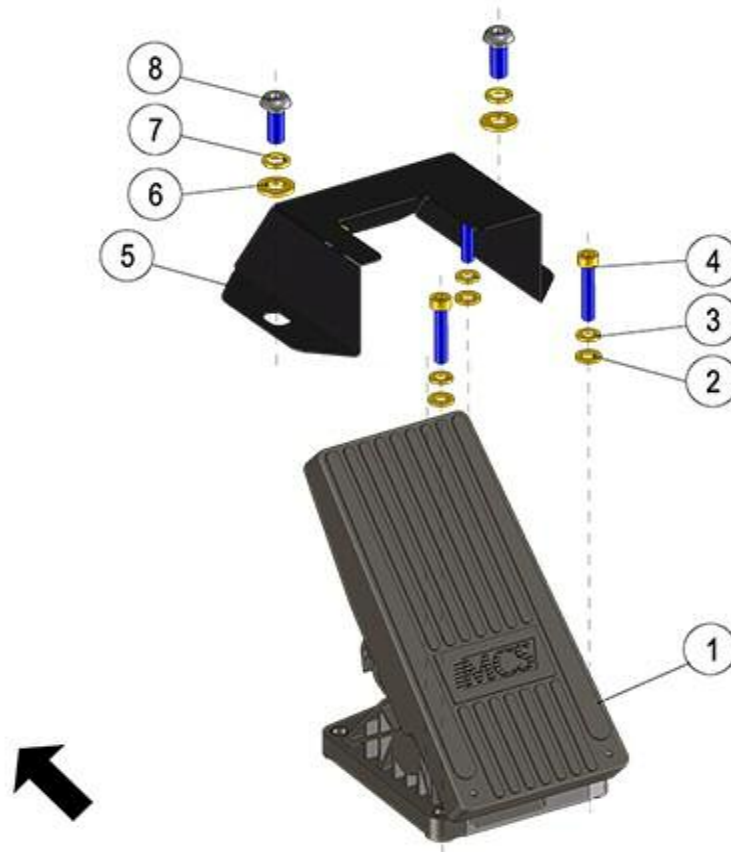

FIGURE	REFERENCE	DENOMINATION	AMOUNT
001	66.11145.00	GAS PEDAL DEUTZ	1
002	101.06000.66	WASHER DIN125 D6	4
003	104.06000.00	WASHER DIN7980 D6	4
004	601.06030.86	HEXAGON SOCKET HEAD SCREW DIN912 M6x30	4
005	66.11111.00	PEDAL COVER CONNECTOR (9005)	1
006	101.08000.66	WASHER DIN125 D8	2
007	104.08000.00	WASHER DIN7980 D8	2
008	630.08020.96	SCREW ISO7380	2

06. STEERING

STEERING (PART 1)

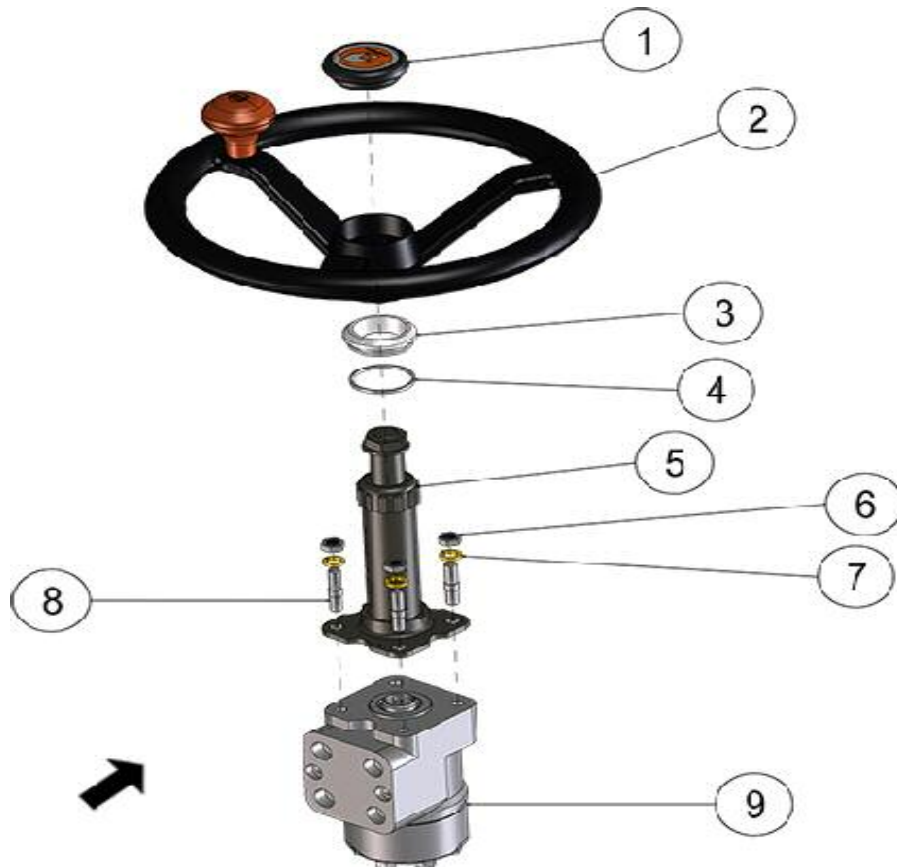

FIGURE	REFERENCE	DENOMINATION	AMOUNT
001	00.00626.05	TRIM	1
002	66.06310.00	STEERING WHEEL	1
003	15.20727.01	NYLON BEARING 17X38X52	1
004	201.03953.50	O-RING DIN3770 D39.5XD3	1
005	66.06300.00	STEERING COLUMN	1
006	701.10000.66	NUT DIN934 M10x1.5	4
007	104.10000.00	WASHER DIN7980 D10	4
008	15.01034.00	STUD DIN938* 41 M10x1,5	4
009	65.06211.01	HYDROSTATIC STEERING	1

06. STEERING

STEERING (PART 2)

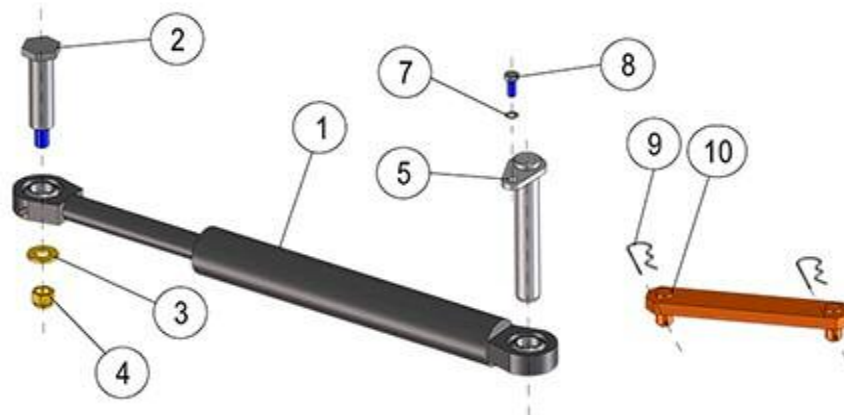

FIGURE	REFERENCE	DENOMINATION	AMOUNT
001	63.06113.00	cylinder	1
001.1	63.06113.90	GASKET SET	1
002	64.04135.00	AXLE	1
003	15.00561.00	WASHER DIN125 20.5x45x5	1
004	711.20000.66	NUT	1
005	66.06200.00	EJE CIL	1
007	104.12000.00	WASHER DIN7980 D12	1
008	603.12030.86	SCREW DIN933 M12x30	1
009	15.00836.02	PIN	2
010	64.06223.00	CON ROD 50x55x300	1

RUEDAS WHEELS



FIGURE	REFERENCE	DENOMINATION	AMOUNT
001A	63.07100DE02	RIGHT WHEEL	2
001B	63.07100IZ02	LEFT WHEEL	2
002	63.07103.00	RIM 16.00X22.5 OFFSET 0	4
003	70.07024.00	VALVE, TUBELESS TR575	4

RUEDAS WHEELS

CHASSIS: 89786



FIGURE	REFERENCE	DENOMINATION	AMOUNT
001A	63.07100DE03	RIGHT WHEEL	2
001B	63.07100IZ03	LEFT WHEEL	2
002	63.07103.02	RIM 16.00X22.5 OFFSET 0	4

08. BODYWORK

SHEETS (1)

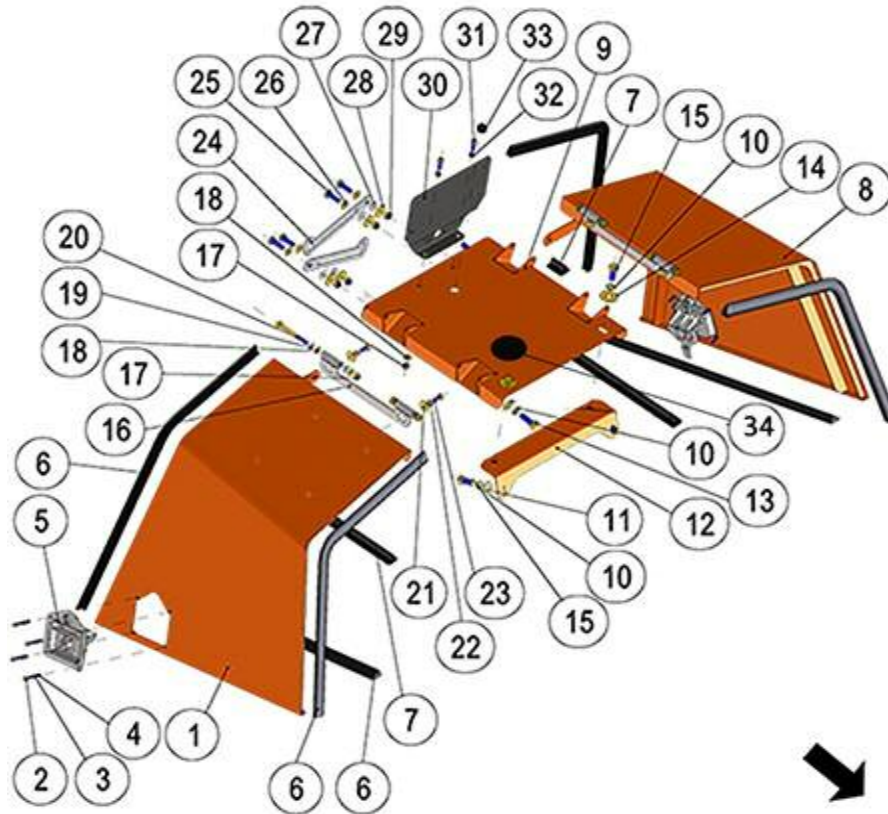

FIGURE	REFERENCE	DENOMINATION	AMOUNT
001	66.08023.00	RIGHT ENGINE COVER	1
002	630.05020.96	SCREW ISO7380	8
003	104.05000.00	WASHER DIN7980 D5	8
004	701.05000.66	NUT DIN934 M5x0.8	8
005	64.08119.00	CLOSING WITH KEY	2
006	472.00410.00	RUBBER PROFILE 22X22	1
007	472.00411.00	RUBBER PROFILE MAT.	1
008	66.08025.00	LEFT ENGINE COVER	1
009	66.08021.00	CENTRAL ENGINE COVER	1
010	104.12000.00	WASHER DIN7980 D12	6
011	101.12000.66	WASHER DIN125 D12	4
012	66.08142.00	SUPPORT ENGINE COVER	1
013	603.12035.86	SCREW DIN933	2
014	112.12000.66	WASHER DIN9021 D 12X36	2
015	603.12030.86	SCREW DIN933 M12x30	4
016	66.08140.00	HINGE 264.5X32X16	2

017	711.08000.66	NUT DIN982 M8	6
018	101.08000.66	WASHER DIN125 D8	10

08. BODYWORK SHEETS (1)

FIGURE	REFERENCE	DENOMINATION	AMOUNT
019	116.08000.00	WASHER DIN125 A D8	8
020	604.08080.86	SCREW DIN931	4
021	112.08000.66	WASHER DIN9021 D8	4
022	104.08000.00	WASHER DIN7980 D8	4
023	603.08020.86	SCREW DIN933 M8x20	4
024	66.08027.00	ENGINE COVER GUIDE	2
025	603.10030.86	SCREW DIN933	4
026	101.10000.66	WASHER DIN125 D10	4
027	116.01000.00	WASHER DIN 125 A D10	4
028	112.10000.66	WASHER DIN9021 D10	4
029	711.10000.66	SHOCK ABSORBER	4
030	66.13300.00	NUMBER PLATE SUPPORT 250x196x30x1.5 (7022)	1
031	603.08025.86	SCREW DIN933 M8x25	2
032	02.32008.00	PLASTIC PLUG	6
033	02.32022.00	CAP	1
034	02.00757.01	CAP	1

08. BODYWORK SHEETS (2)

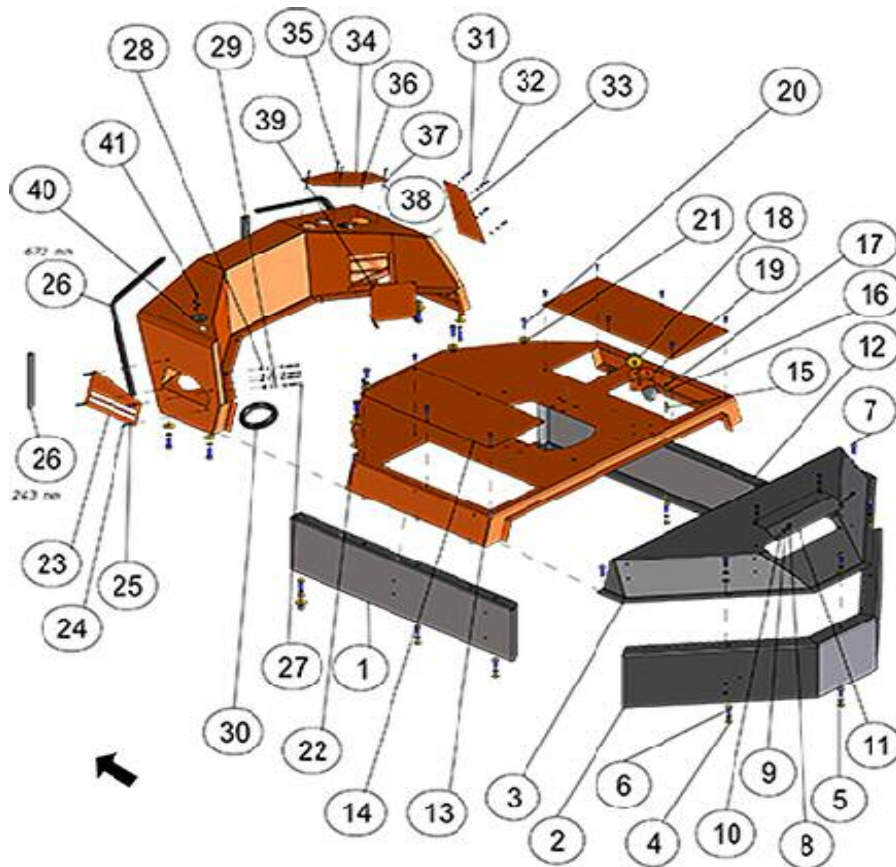

FIGURE	REFERENCE	DENOMINATION	AMOUNT
001	66.08071.00		1
002	66.08061.00		1
003	66.08080.00	SHEET	1
004	101.12000.66	WASHER DIN125 D12	12
005	104.12000.00	WASHER DIN7980 D12	20
006	603.12030.86	SCREW DIN933 M12x30	7
007	630.12025.87	SCREW ISO7380 M12X25	5
008	630.08020.96	SCREW ISO7380	21
009	104.08000.00	WASHER DIN7980 D8	4
010	101.08000.66	WASHER DIN125 D8	12
011	66.08082.00	SHEET	1
012	66.08072.00		1
013	66.08090.00	SHEET	1
014	66.08079.00	SHEET	2
015	15.01034.00	STUD DIN938* 41 M10x1,5	6
016	112.10000.66	WASHER DIN9021 D10	6

017	104.10000.00	WASHER DIN7980 D10	6
018	08.00107.01	BUTT	2

08. BODYWORK SHEETS (2)

FIGURE	REFERENCE	DENOMINATION	AMOUNT
019	66.08106.00	SHEET	1
020	603.12035.86	SCREW DIN933	8
021	112.12000.66	WASHER DIN9021 D 12X36	14
022	701.12000.66	NUT DIN934 M12x1.75	8
023	66.08084.00	SHEET	1
024	630.06020.96	SCREW ISO7380 M6x20	4
025	104.06000.00	WASHER DIN7980 D6	4
026	472.00410.00	RUBBER PROFILE 22X22	4
027	630.08035.96	TORNILLO ISO7380	4
028	711.08000.66	NUT DIN982 M8	4
029	66.08053.00	ACOUSTIC SIGNAL COVER FVS	1
030	472.00411.00	RUBBER PROFILE MAT.	1
031	630.06015.96	SCREW ISO7380 M6x15	8
032	101.06000.66	WASHER DIN125 D6	8
033	66.08086.00	SHEET	1
034	66.08109.00	SHEET	1
035	603.04020.87	SCREW DIN 933 M4X20	5
036	104.04000.00	WASHER DIN7980 D4	5
037	101.04000.66	WASHER DIN125 D4	10
038	701.04000.66	NUT DIN934 M4	7
039	66.08085.00	SHEET	1
040	66.08057.00	ACOUSTIC SIGNAL BUTTON COVER FVS	1
041	630.04015.97	SCREW M4x15 ISO7380	2

08. BODYWORK SHEETS (3)

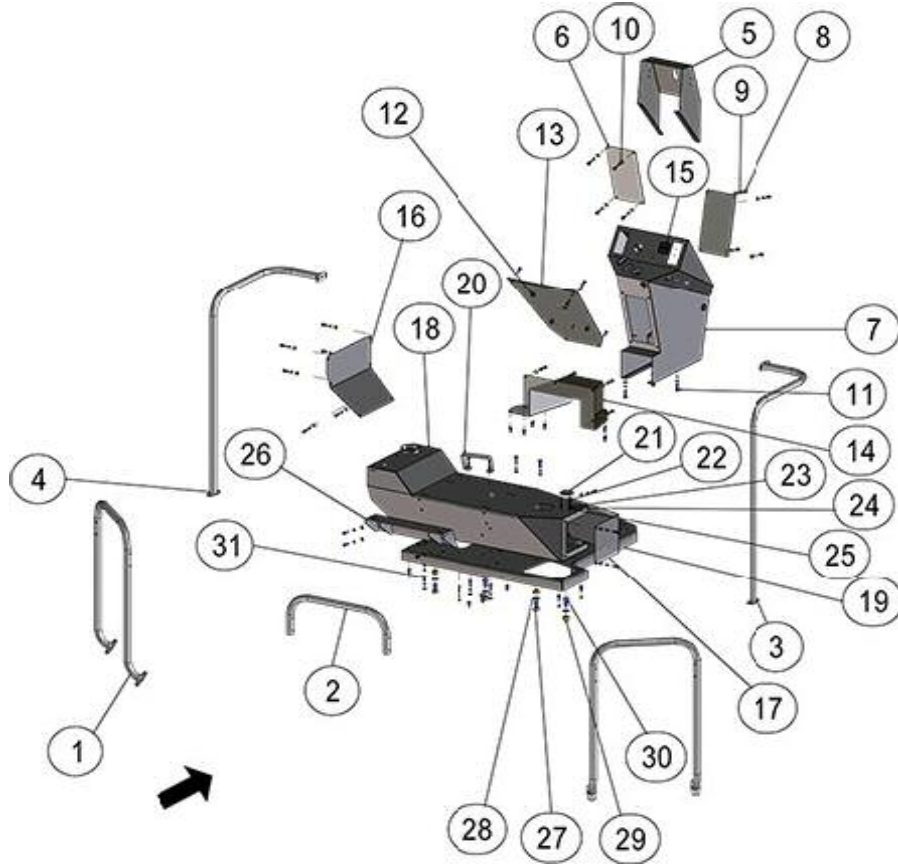

FIGURE	REFERENCE	DENOMINATION	AMOUNT
001	66.08098.00	HANDLE	2
002	66.08100.00	HANDLE	1
003	66.08099.00	HANDLE	1
004	66.08097.00	HANDLE	1
005	66.08081.00	SHEET	1
006	66.08077.00	SHEET	2
007	66.08096.00	SHEET	1
008	630.08020.96	SCREW ISO7380	51
009	104.08000.00	WASHER DIN7980 D8	48
010	101.08000.66	WASHER DIN125 D8	51
011	603.08030.86	SCREW DIN933 M8X30	6
012	711.08000.66	NUT DIN982 M8	4
013	66.08076.00	SHEET	1
014	66.08073.00	SHEET	1
015	12.11024.00	SWITCH CAP	3
016	66.08074.00	SHEET	1

017	66.08075.00	SHEET	1
018	66.08095.00	SHEET	1

08. BODYWORK SHEETS (3)

FIGURE	REFERENCE	DENOMINATION	AMOUNT
019	66.08094.00	SHEET	1
020	70.08039.00	SUPPORT	1
021	32.08164.00	MACHINE LEVELING INDICATOR	1
022	601.04020.87	SCREW DIN912 M4x20	3
023	24.08287.00	SHOCK ABSORBER	3
024	711.04000.66	NUT	3
025	101.04000.66	WASHER DIN125 D4	3
026	66.08305.00	SHEET	1
027	603.14035.86	SCREW DIN933	2
028	101.14000.66	WASHER DIN125 D14	4
029	711.14000.66	NUT DIN982 M14 8.8 K	4
030	630.14035.96	SCREW	2
031	603.08025.86	SCREW DIN933 M8x25	4

08. BODYWORK

LOAD PROTECTOR

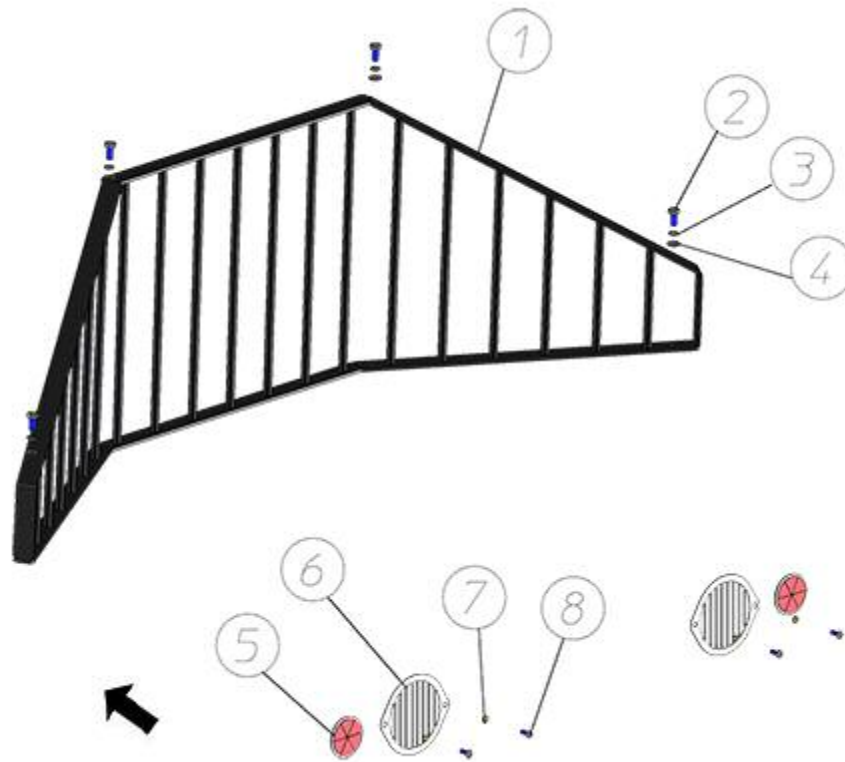

FIGURE	REFERENCE	DENOMINATION	AMOUNT
001	66.09410.00	PROTECTOR	1
002	603.12025.86	SCREW DIN933	4
003	104.12000.00	WASHER DIN7980 D12	4
004	101.12000.66	WASHER DIN125 D12	4
005	10.11017.00	RED REFLECTOR	2
006	66.08028.00	BULB GUARD FRONTAL LIGHT	2
007	104.08000.00	WASHER DIN7980 D8	4
008	630.08020.96	SCREW ISO7380	4

08. BODYWORK

ROPS ARCH

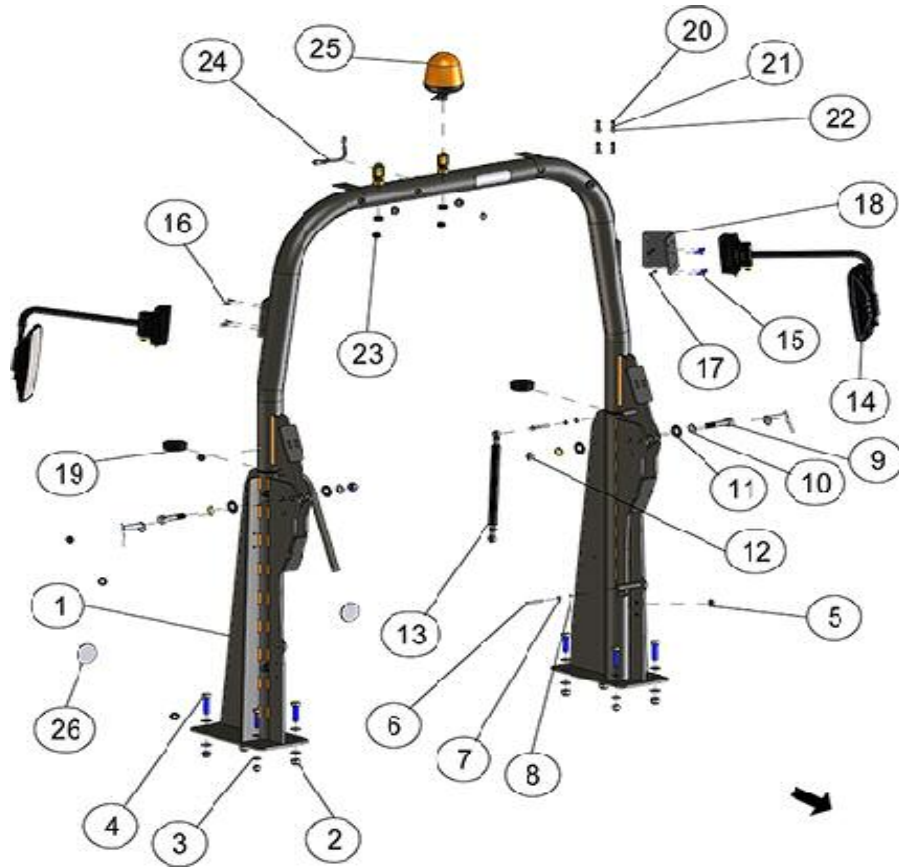

FIGURE	REFERENCE	DENOMINATION	AMOUNT
001	66.08165.00	ROPS arch	1
002	711.18000.66	NUT DIN982 M18	8
003	101.18000.66	BEARING DIN125 D18	16
004	604.18070.86	SCREW DIN931	8
005	43.07777.00	GROMMET	4
006	603.10060.86	SCREW DIN933	2
007	104.10000.00	WASHER DIN7980 D10	2
008	101.10000.66	WASHER DIN125 D10	2
009	604.20090.86	SCREW	2
010	101.20000.66	WASHER DIN125	4
011	116.20000.00	WASHER 20 DIN125 ZN	4
012	720.20000.66	NUT DIN985 M20x1.5	2
013	32.08026.00	SHOCK ABSORBER, L746xC290 2200 N	1
014	66.08251.00	REAR-VIEW MIRROR	2
015	618.08025.86	SCREW DIN7991	4
016	618.08020.86	SCREW DIN7991 M8x20	4

017	720.08000.66	NUT DIN985 M8 AUTOLOCKING	4
018	66.08252.00	SHEET	1

08. BODYWORK

ROPS ARCH

FIGURE	REFERENCE	DENOMINATION	AMOUNT
019	66.08180.00	CAP	2
020	603.08020.86	SCREW DIN933 M8x20	4
021	104.08000.00	WASHER DIN7980 D8	4
022	101.08000.66	WASHER DIN125 D8	4
023	13.04026.00	CAP	3
024	46.11154.00	ROTATIVE BEACON ELECTRICAL LENGHT	1
025	01.00912.00	BEACON	1
026	10.11017.00	RED REFLECTOR	2

08. BODYWORK SEAT



FIGURE	REFERENCE	DENOMINATION	AMOUNT
001	66.08240.00	REDUCED HEIGHT SEAT WITH SENSOR	1
001.1	57.08003.02	SENSOR SEAT	1
001.2	46.11033.06	CONNECTOR	1
002	66.08241.00	ORANGE SEAT BELT WITH SENSOR	1
003	630.08020.96	SCREW ISO7380	4
004	112.08000.66	WASHER DIN9021 D8	4
005	711.08000.66	NUT DIN982 M8	4

08. BODYWORK COUNTERWEIGHT

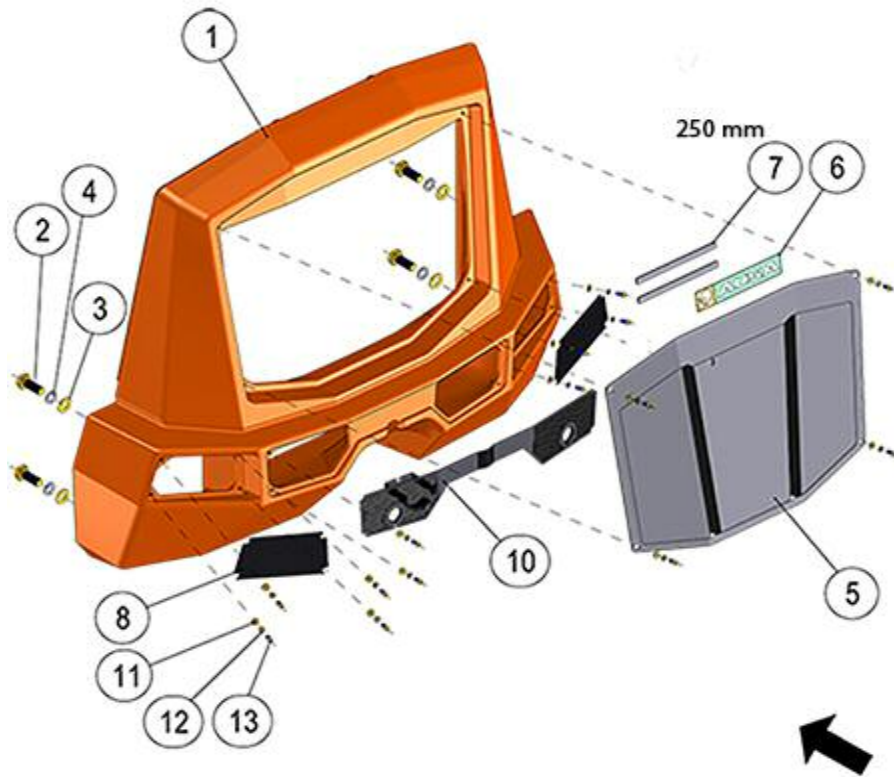

FIGURE	REFERENCE	DENOMINATION	AMOUNT
001	66.08010.00	COUNTERWEIGHT	1
002	603.20050.86	SCREW DIN933	4
003	101.20000.66	WASHER DIN125	4
004	104.20000.00	CIR-CLIP EXT. DIN7980	4
005	66.08011.02	RADIATOR PROTECTOR	1
006	00.00015.00	AUSA CORP. STICKER	1
006	00.00015.00	AUSA CORP. STICKER	1
007	472.04015.00	RUBBER PROFILE MAT.	2
008	66.08013.01	COVER	2
010	66.08012.01	PROTECTION	1
011	101.08000.66	WASHER DIN125 D8	12
012	104.08000.00	WASHER DIN7980 D8	16
013	630.08015.96	SCREW ISO7380	16

08. BODYWORK

JOYSTICK LEVER

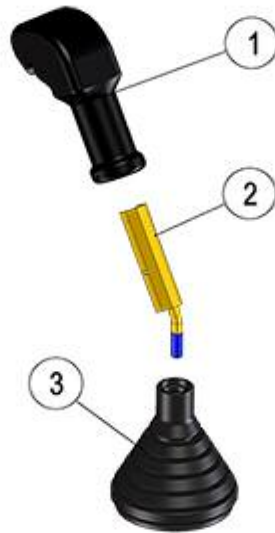

FIGURE	REFERENCE	DENOMINATION	AMOUNT
001	66.11108.00	JOYSTICK	1
002	10.13154.02	AXIS CIL/ROS 180XD25XM10	1
003	43.50349.00	DUST PROTECTOR	1

09. MACHINE FUNCTIONS IMPLEMENTS

HOPPER

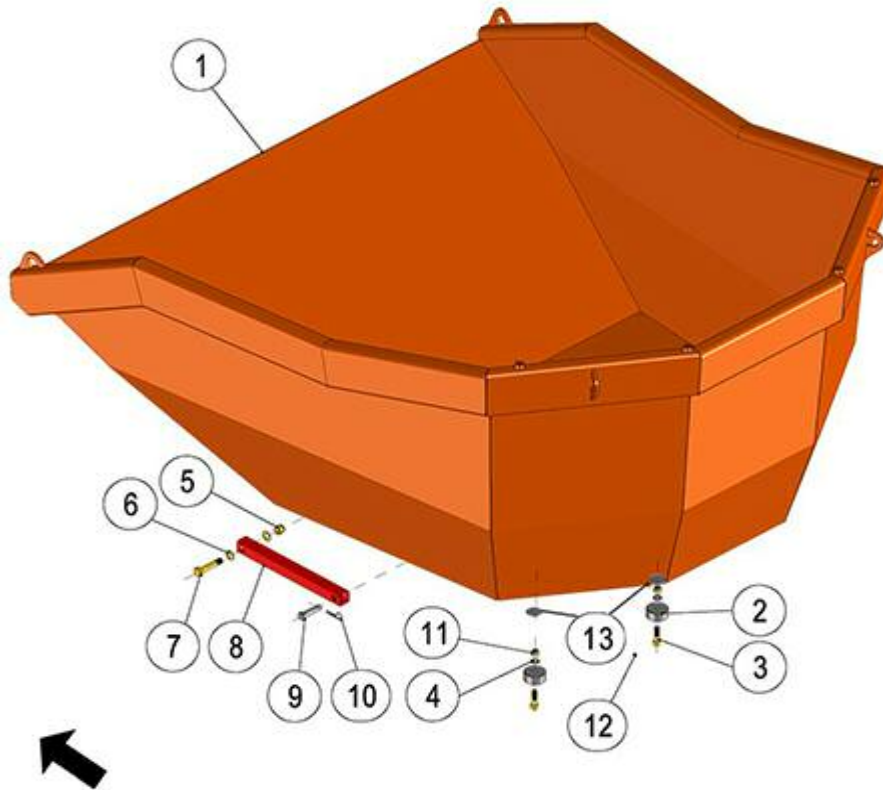

FIGURE	REFERENCE	DENOMINATION	AMOUNT
001	66.09400.00		1
002	20.03003.00	SHOCK ABSORVER SUPPORT	2
003	601.16060.86	HEXAGON SOCKET HEAD SCREW DIN912 M16x60	2
004	101.16000.66	WASHER DIN125 D16	2
005	711.20000.66	NUT	1
006	101.20000.66	WASHER DIN125	2
007	604.20100.86	SCREW DIN931	1
008	64.09215.00	SUPPORT 50x50x5, HOSE GUIDE	1
009	64.09216.00	SHAFT CYL/CYL 30x20x90	1
010	15.00836.00	PIN DIN11024 R4	1
011	711.16000.66	NUT DIN982 M16 8.8 K	2
012	02.32008.00	PLASTIC PLUG	2
013A	43.70833.00	WASHER 65X16X5	0
013B	63.04428.00		0

09. MACHINE FUNCTIONS IMPLEMENTS

ROTATING HOPPER SUPPORT

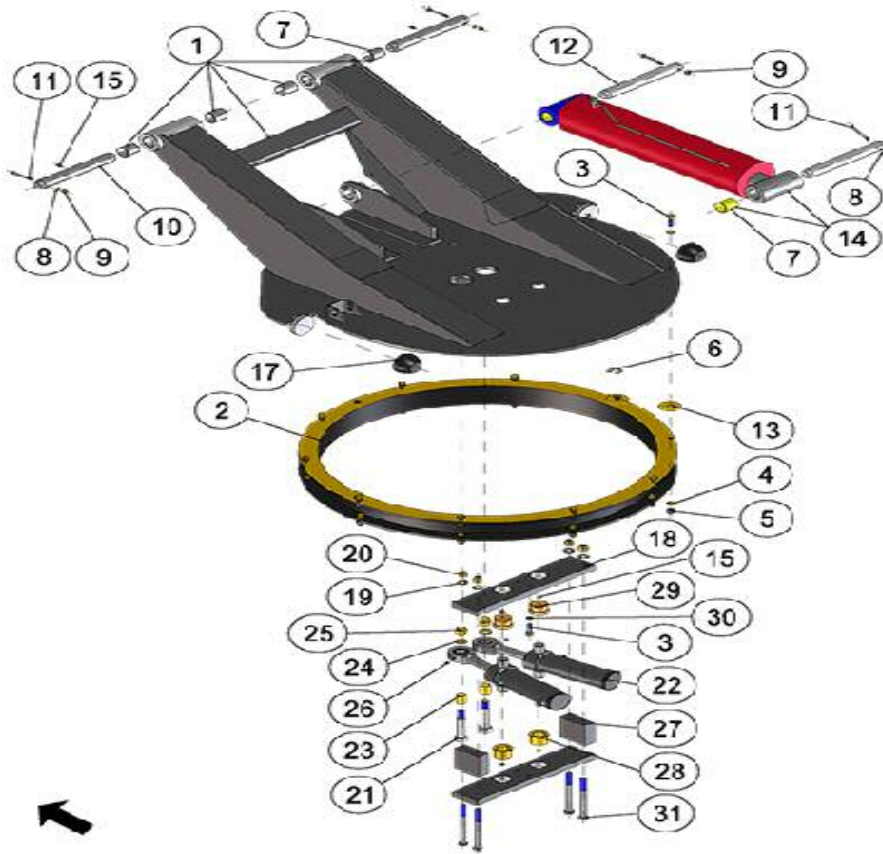

FIGURE	REFERENCE	DENOMINATION	AMOUNT
001	66.04301.00		1
002	64.09212.00	CYL. CROWN	1
003	604.12045.96	SCREW DIN931 M12x45	21
004	101.12000.66	WASHER DIN125 D12	40
005	711.12000.86	NUT DIN982 M12 C8	20
006	64.09218.00	SUPPLY 0,5X14	1
007	949.04050.00	PLAIN BEARING 40X44X50 DIN 1494	4
008	101.08000.66	WASHER DIN125 D8	3
009	711.08000.66	NUT DIN982 M8	4
010	64.09211.00	AXLE CYL/CYL	2
011	603.08075.86	SCREW DIN933	4
012	63.09115.00	CYL/CYL AXLE 35X335	2
013	43.70833.00	WASHER 65X16X5	2
014	63.09113.00	CYLINDER 160X578	1
014.1	63.09113.10	GASKET SET, CYLINDER	1
015	901.08000.33	GREASER DIN71412-A M8x1,25	6

016	949.03540.00	BUSHING 35x40 DIN 1494	4
017	64.08021.00	PROGRESSIVE SHOCK ABSORBER	2

09. MACHINE FUNCTIONS IMPLEMENTS

ROTATING HOPPER SUPPORT

FIGURE	REFERENCE	DENOMINATION	AMOUNT
018	64.04226.00	SUPPORT 25x100x490, FIXING	2
019	101.16000.66	WASHER DIN125 D16	4
020	711.16000.86	NUT DIN982 M16 C8	4
021	64.04225.00	SHAFT 36x20x140	2
022	64.09214.03	CYLINDER D/E 70X152X351	2
022.1	64.09214.10	NOT AVAILABLE	2
023	64.04230.00	BUSHING 2.5x25x30	2
024	101.20000.66	WASHER DIN125	2
025	711.20000.66	NUT	2
026	43.50129.00	CAP	2
027	64.04227.00	SUPPORT 50x100x100, FIXING	2
028	64.04228.00	BUSHING 9,5x32x51	2
029	64.04229.01	BUSHING 32x51x56	2
030	104.12000.00	WASHER DIN7980 D12	1
031	604.16190.97	SCREW DIN931 M16X190 12K	4

10. HYDRAULIC INSTALLATION PUMPS

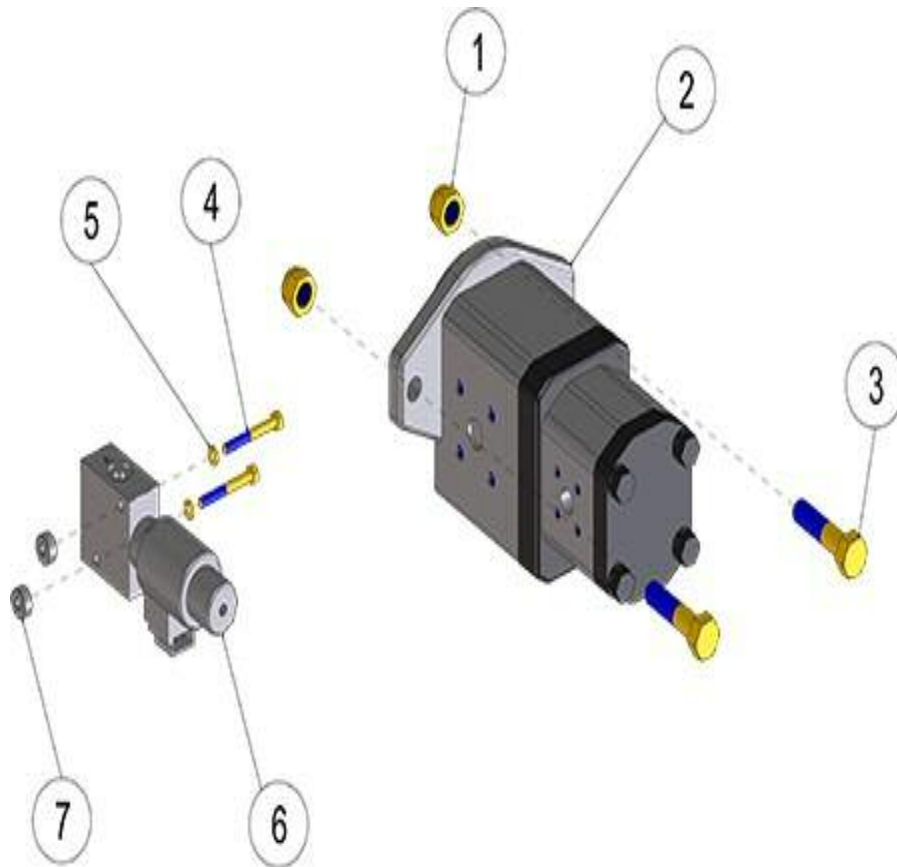

FIGURE	REFERENCE	DENOMINATION	AMOUNT
001	711.14000.66	NUT DIN982 M14 8.8 K	2
002	66.10100.00	DOUBLE HYDR. PUMP 24CC	1
003	604.14060.86	SCREW DIN931	2
004	604.06050.86	SCREW DIN931	2
005	104.06000.00	WASHER DIN7980 D6	2
006	46.15005.00	3 WAY SELECTOR VALVE DEUTSCH	1
007	20.10010.01	PIN SUPPORT 8X17	2

10. HYDRAULIC INSTALLATION DISTRIBUTOR

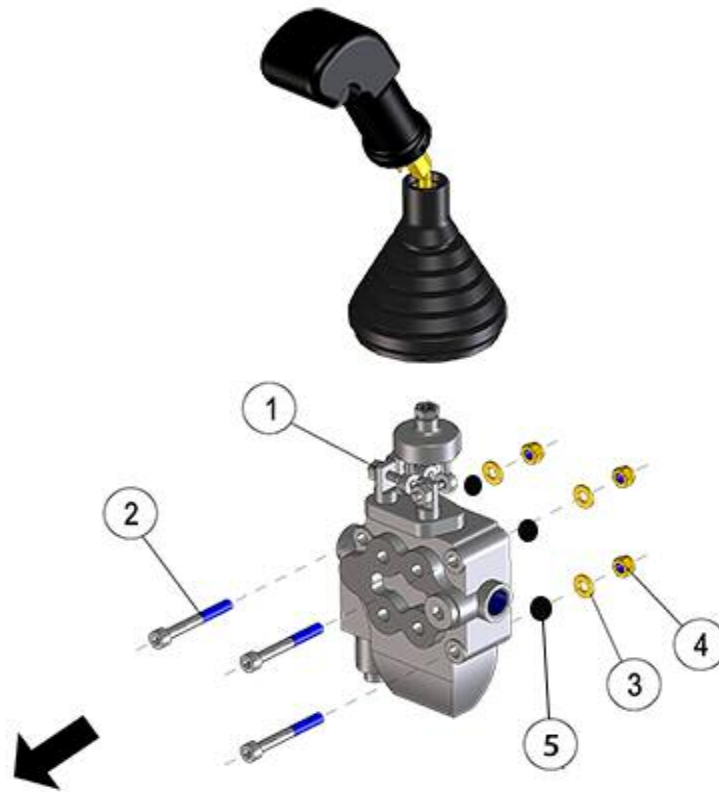

FIGURE	REFERENCE	DENOMINATION	AMOUNT
001	66.10302.00	DISTRIBUTOR 2/E LIMITER	1
002	601.08065.86	SCREW DIN912 M8x65	3
003	101.08000.66	WASHER DIN125 D8	3
004	711.08000.66	NUT DIN982 M8	3
005	104.08000.00	WASHER DIN7980 D8	3

10. HYDRAULIC INSTALLATION VALVES

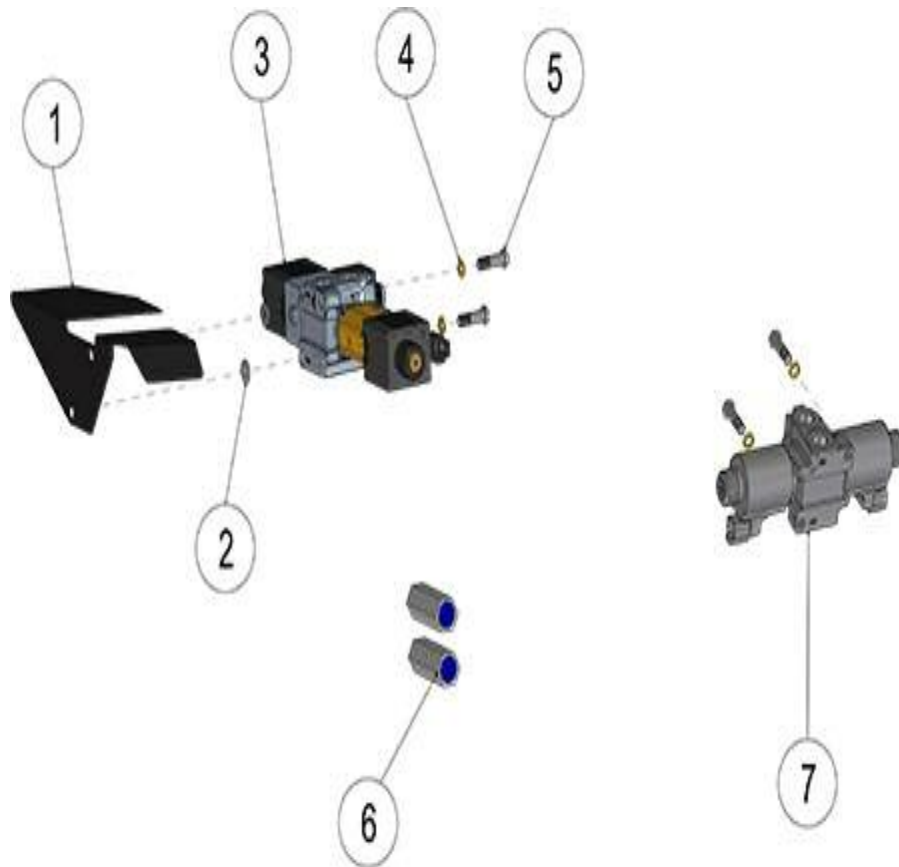

FIGURE	REFERENCE	DENOMINATION	AMOUNT
001	66.10401.00	SHEET	1
002	101.08000.66	WASHER DIN125 D8	2
003	66.10484.00	VALVE	1
004	104.08000.00	WASHER DIN7980 D8	4
005	630.08030.96	BOLT ISO7380 M8x30	4
006	64.10326.11		2
007	48.10490.00	SOLENOID	1

10. HYDRAULIC INSTALLATION TANK

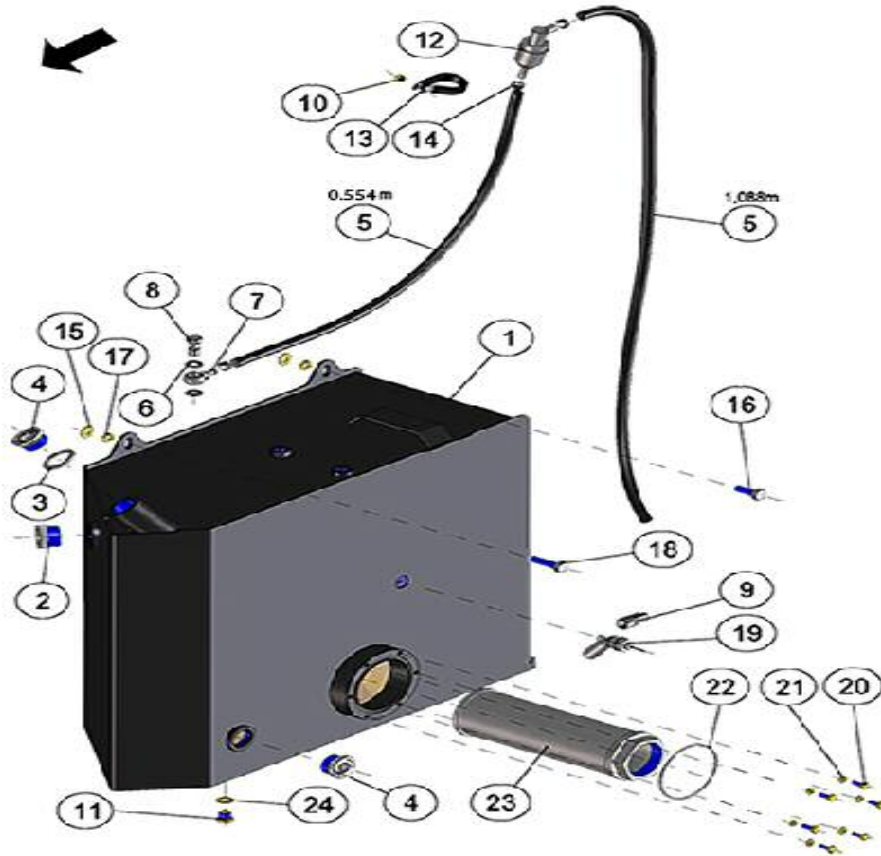

FIGURE	REFERENCE	DENOMINATION	AMOUNT
001	66.10050.01	OIL TANK 65L	1
002	30.10041.00	LEVEL VISUAL INDICATOR 1	1
003	43.13444.00	GASKET MET. BUNA	1
004	70.10246.01	PLUG 1 GAS TORQUE OF TIGHTENING	1
005	469.25015.00	TUBE MAT. B/P 10x15	1
006	28.00341.00	METALLIC GASKET BUNA D1/4	2
007	45.04106.00	NIPPLE O/TB	1
008	28.00340.00	SIMPLE SCREW FITTING 1/4 Gx26	1
009	46.11033.00		1
010	711.06000.66	NUT DIN982 M6	1
011	603.10025.86	SCREW DIN933 M10x25	2
012	45.01526.00	PREFILTER FUEL/HYDRAULIC	1
013	830.03006.00	CLAMP LOOP	1
014	948.01408.00	CLAMP Ø14	3
015	101.10000.66	WASHER DIN125 D10	2
016	603.10030.86	SCREW DIN933	1

017	104.10000.00	WASHER DIN7980 D10	2
018	603.10040.86	BOLT DIN933 M10x40	1

10. HYDRAULIC INSTALLATION TANK

FIGURE	REFERENCE	DENOMINATION	AMOUNT
019	43.70261.00	OIL LEVEL INDICATOR BUOY	1
020	603.06015.86	SCREW DIN933 M6x15	6
021	104.06000.00	WASHER DIN7980 D6	6
022	201.95003.50	O-RING DIN3770	1
023	46.10047.00	OIL FILTER 180 L	1
024	112.10000.66	WASHER DIN9021 D10	2

10. HYDRAULIC INSTALLATION OIL TANK

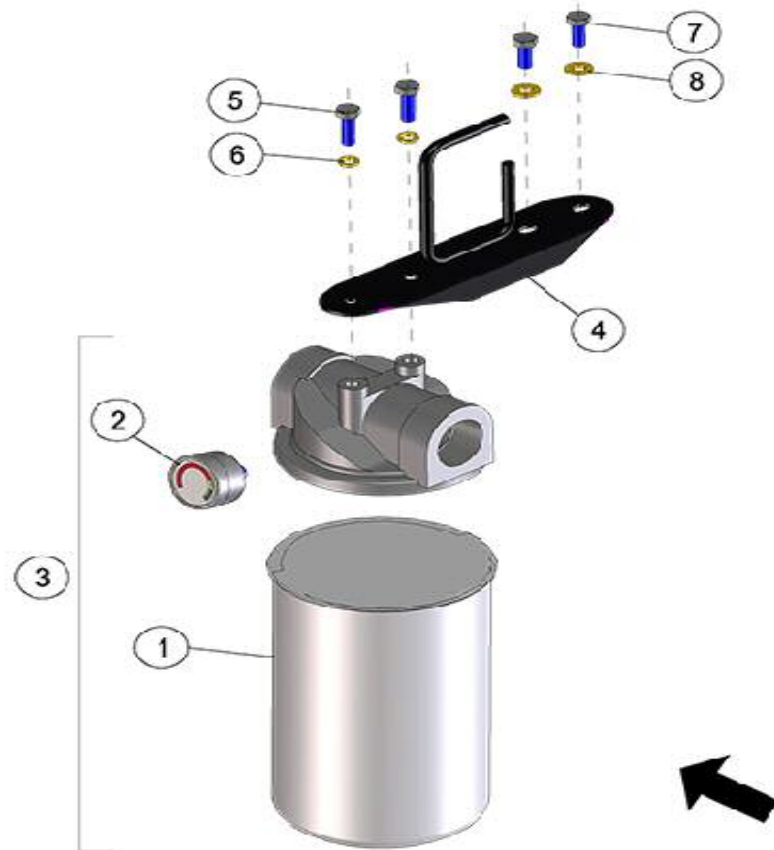

FIGURE	REFERENCE	DENOMINATION	AMOUNT
001	60.20100.00	FILTER ELEMENT	1
002	60.20102.00	INDICATOR	1
003	60.20101.00	COMPLETE OIL FILTER	1
005	603.08025.86	SCREW DIN933 M8x25	2
006	104.08000.00	WASHER DIN7980 D8	2
007	603.08020.86	SCREW DIN933 M8x20	2
008	101.08000.66	WASHER DIN125 D8	2

10. HYDRAULIC INSTALLATION

STANDARD HYDRAULIC DIAGRAM

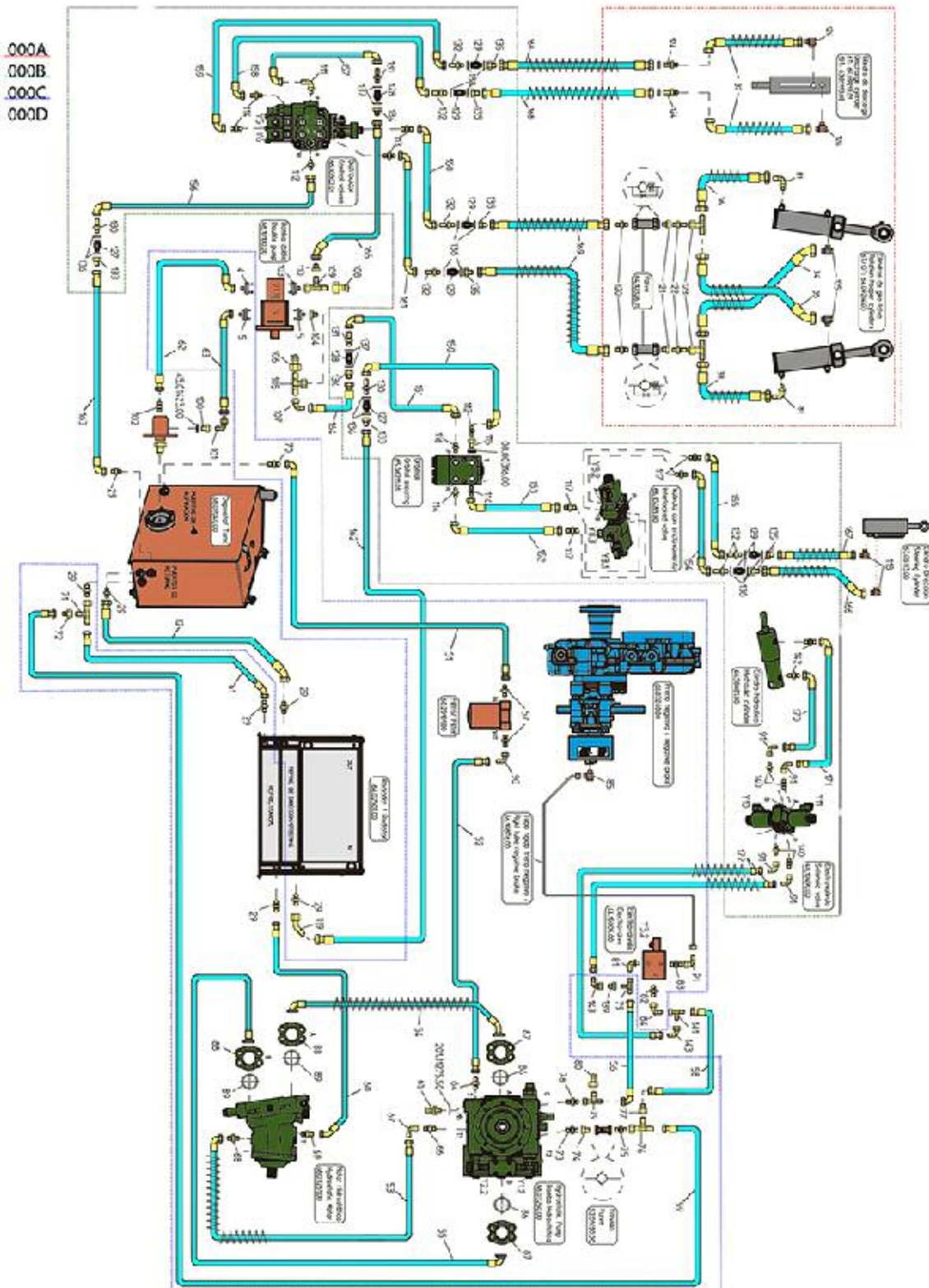

FIGURE	REFERENCE	DENOMINATION	AMOUNT
--------	-----------	--------------	--------

000A	66.13140.00	REV. ROTATORY HOPPER	1
000B	66.13120.00	REVERSIBLE MODULE	1
000C	66.10850.00	MOTOR SUPPLY REV.	1
000D	66.13150.00	MOTOR SUPPLY REV.	1
004	66.10808.00	FLANGE RGB STRAIGHT D40 MM M36	1
005	48.10026.00	FLANGE	2
012	66.10812.00	TUBE (EN853-1SN)-3/4" 1240 TL	1
029	57.10307.00	FITTING	7
033	66.10833.00	TUBE (EN853-1SN)-5/16" 630 CO	1
034	66.10834.00	TUBE (EN853-1SN)-5/16" 700 CO	1
035	66.10835.00	TUBE (EN853-1SN)-5/16" 635 CO	1
036	66.10836.00	TUBE (EN853-1SN)-5/16" 575 CO	1
037	66.10837.00	TUBE (EN853-1SN)-3/8" 595 CON	2
051	66.10851.00	PIPE R4-1.1/4"625TLC90M45X2 35L	1
052	66.10852.00	TUBE (SAE100-R4)-1.1/4" 880 TL-	1
053	66.10853.00	TUBE (EN857-1SC)-3/4" 1905 TL-	1
054	66.10854.00	TUBE (EN856-4SH)-1" 1065 BD45	1
055	66.10855.00	TUBE (EN856-4SH)-1" 1165 BD90	1
056	66.10856.00	TUBE (EN853-1SN)-1/4" 530 TL-	1
057	66.10866.00	MB/M MB1 1/4"BSP-MM M45X2L35	2
058	66.10858.00	TUBE (EN853-1SN)-1/4" 510 TL-	1
059	66.10859.00	PIPE 1/2"480TL-TL M22x1.5-15L	1
060	66.10860.00	TUBE (EN853-1SN)-3/4" 1750 TL-	1
061	66.10861.00	TUBE (EN853-1SN)-3/4" 1165 TL-	1
062	66.10862.00	TUBE (SAE100-R17)-1" 625 TL- C	1
063	66.10863.00	TUBE (SAE100-R17)-1" 655 TL- C	1
064	66.10867.00	FITTING MB M42X2-MM M45X2	1
065	66.10868.00	HOSE COUP. MM M14X1.5	1
066	48.10408.00	RACCORD M/M	1
067	46.58004.00	FITTING	1
068	66.10804.00	MB M33X2-MM M30X2 L22	1
069	66.10819.00	FITTING	1
070	66.10865.00	MB/M MB 1" BSP-MM M45X2 L35	1
071	57.10311.00	FITTING	1
072	48.10453.00	RACOR M/TL -MF M22X1,5 / TL M3	1
073	48.10445.00	RACOR M/M MB26X1,5-MM M26X1.5	1

10. HYDRAULIC INSTALLATION

STANDARD HYDRAULIC DIAGRAM

FIGURE	REFERENCE	DENOMINATION	AMOUNT
074	48.10234.00	"RACOR M/TL MF1/2""BSP / M26X1,5"	1
075	48.10235.00	RACOR M/M -1/2"BSP / M22X1,5	1
076	46.10911.00	FITTING	1
077	46.60251.00	FITTING	1
078	48.10943.00	RACOR	1
079	46.10401.00	FITTING	2
080	46.10402.00	COUPLING	1
081	48.10313.00	FITTING	3
082	66.10875.00	FITTING MB/M MB 1/4" BSP-MM M14	1
083	17.10169.00		1
084	46.58112.00		1
085	66.10869.00	C90TO/M MB M10X1-MM M12X1.5L6	1
086	30.10302.00	GASKET 1	2
087	46.10845.00	CLAMP SAE6000 1	2
088	66.10801.00	FITTING	2
089	66.10802.00	RUBBER SEAL REC. POLIU.1 1/4"	2
090	48.10322.00	FITTING C90M/TL M45X2	1
091	33.10201.00	C90M/TL CONNECTOR M12X1, 5	5
100	46.60233.91	FITTING	1
101	66.10805.00	FITTING C90MO/M MB3/4"BSP-M36x2	1
102	12.10301.00	FITTING	1
103	66.10807.00	FLANGE RGB-REC-D35MM-M22Junta	1
104	48.10423.00	FITTING	1
105	48.10326.00	FITTING	1
106	64.10227.00	FITTING	1
107	48.10223.00	FITTING	1
108	64.10226.00	FITTING	1
109	46.10911.00	FITTING	1
110	66.10803.00	FITTING M/TL MM M26X1.5 (L18) TL	1
111	20.10550.00	FITTING	1
112	48.10437.00	FITTING	2
113	46.10825.00	FITTING	2
114	70.10229.00	FITTING	4
115	39.05924.00	FITTING	1
116	48.10433.00	FITTING	1
117	48.10836.00	RACOR M/M MB 3/8 BSP - MM M18L	4

10. HYDRAULIC INSTALLATION

STANDARD HYDRAULIC DIAGRAM

FIGURE	REFERENCE	DENOMINATION	AMOUNT
118	66.10800.00	RACOR	2
119	46.10450.00	FITTING	1
120	46.10849.00	FITTING	2
121	30.10335.00	FITTING	2
122	48.10109.00	FITTING	2
123	70.10258.00	FITTING	2
124	70.10255.00	FITTING	2
125	48.10764.00	FITTING	2
126	48.10934.00	FITTING	2
127	66.13134.00	FITTING	2
128	66.13135.00	FITTING	2
129	66.13136.00	FITTING	6
130	66.10891.00	FITTING	2
131	66.10892.00	FITTING	2
132	66.10893.00	FITTING	6
133	66.10894.00	FITTING	2
134	66.10895.00	FITTING	2
135	48.10858.00	FITTING	6
136	45.01423.00	GASKET	4
137	08.00316.00	METALLIC GASKET BUNA D1/2 G	4
138	08.00317.00	METALLIC GASKET BUNA D3/8	12
139	20.10440.00	FITTING	1
140	46.58181.00	FITTING	4
141	48.10320.00	RACOR FORT M/M/TL -M14X1,5	1
142	48.10351.00	FITTING M/M 1/8 BSP M12X1.5	2
143	46.58112.00		2
150	66.13151.00	TUBE	1
151	66.13152.00	TUBE	1
152	66.13153.00	TUBE	1
153	66.13154.00	TUBE	1
154	66.13155.00	TUBE	1
155	66.13156.00	TUBE	1
156	66.13157.00	TUBE	1
157	66.13158.00	TUBE	1

158	66.13159.00	TUBE	1
159	66.13160.00	TUBE	1

10. HYDRAULIC INSTALLATION

STANDARD HYDRAULIC DIAGRAM

FIGURE	REFERENCE	DENOMINATION	AMOUNT
160	66.13161.00	TUBE	1
161	66.13162.00	TUBE	1
162	66.13163.00	TUBE	1
163	66.13164.00	TUBE	1
164	66.13165.00	TUBE	1
165	66.13166.00	TUBE	1
166	66.13167.00	TUBE	1
167	66.13168.00	TUBE	1
168	66.13169.00	TUBE	2
169	66.13170.00	TUBE	2
170	66.13171.00	TUBE	1
171	66.13172.00	TUBE	1
172	66.13173.00	TUBE	2

10. HYDRAULIC INSTALLATION

STANDARD HYDRAULIC DIAGRAM

CHASSIS: 93853

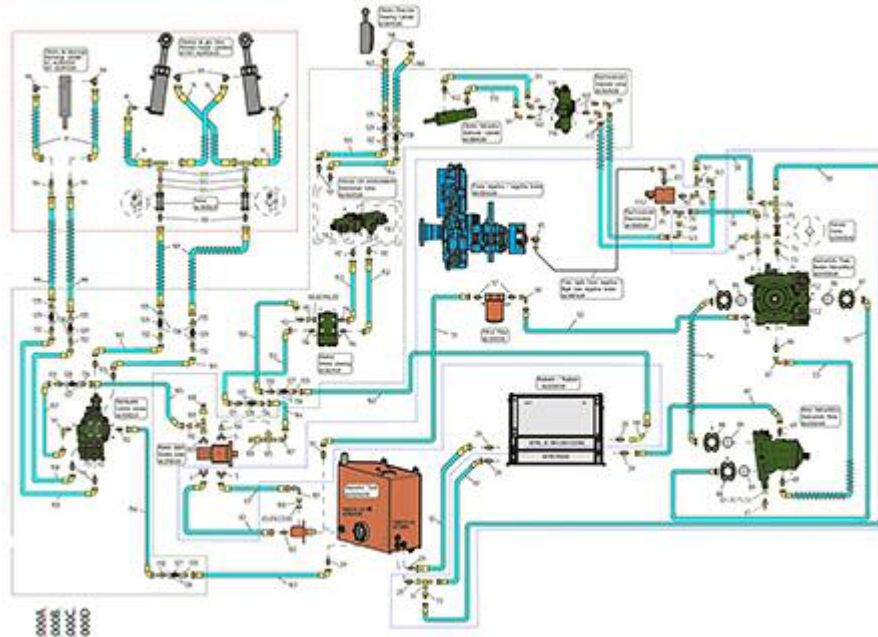

FIGURE	REFERENCE	DENOMINATION	AMOUNT
000A	66.13140.00	REV. ROTATORY HOPPER	1
000B	66.13120.00	REVERSIBLE MODULE	1
000C	66.10850.00	MOTOR SUPPLY REV.	1
000D	66.13150.00	MOTOR SUPPLY REV.	1
004	66.10808.00	FLANGE RGB STRAIGHT D40 MM M36	1
005	48.10026.00	FLANGE	2
012	66.10812.00	TUBE (EN853-1SN)-3/4" 1240 TL	1
029	57.10307.00	FITTING	7
033	66.10833.00	TUBE (EN853-1SN)-5/16" 630 CO	1
034	66.10834.00	TUBE (EN853-1SN)-5/16" 700 CO	1
035	66.10835.00	TUBE (EN853-1SN)-5/16" 635 CO	1
036	66.10836.00	TUBE (EN853-1SN)-5/16" 575 CO	1
037	66.10837.00	TUBE (EN853-1SN)-3/8" 595 CON	2
051	66.10851.00	PIPE R4-1.1/4"625TLC90M45X2 35L	1
052	66.10852.00	TUBE (SAE100-R4)-1.1/4" 880 TL-	1
053	66.10853.00	TUBE (EN857-1SC)-3/4" 1905 TL-	1
054	66.10854.00	TUBE (EN856-4SH)-1" 1065 BD45	1
055	66.10855.00	TUBE (EN856-4SH)-1" 1165 BD90	1
056	66.10856.00	TUBE (EN853-1SN)-1/4" 530 TL-	1
057	66.10866.00	MB/M MB1 1/4"BSP-MM M45X2L35	2
058	66.10858.00	TUBE (EN853-1SN)-1/4" 510 TL-	1

059	66.10859.00	PIPE 1/2"480TL-TL M22x1.5-15L	1
060	66.10860.00	TUBE (EN853-1SN)-3/4" 1750 TL-	1
061	66.10861.00	TUBE (EN853-1SN)-3/4" 1165 TL-	1
062	66.10862.00	TUBE (SAE100-R17)-1" 625 TL- C	1
063	66.10863.00	TUBE (SAE100-R17)-1" 655 TL- C	1
064	66.10867.00	FITTING MB M42X2-MM M45X2	1
065	66.10868.00	HOSE COUP. MM M14X1.5	1
066	48.10408.00	RACCORD M/M	1
067	46.58004.00	FITTING	1
068	66.10804.00	MB M33X2-MM M30X2 L22	1
069	66.10819.00	FITTING	1
070	66.10865.00	MB/M MB 1" BSP-MM M45X2 L35	1
071	57.10311.00	FITTING	1
072	48.10453.00	RACOR M/TL -MF M22X1,5 / TL M3	1
073	48.10445.00	RACOR M/M MB26X1,5-MM M26X1.5	1

10. HYDRAULIC INSTALLATION

STANDARD HYDRAULIC DIAGRAM

CHASSIS: 93853

FIGURE	REFERENCE	DENOMINATION	AMOUNT
074	48.10234.00	"RACOR M/TL MF1/2""BSP / M26X1,5"	1
075	48.10235.00	RACOR M/M -1/2"BSP / M22X1,5	1
076	46.10911.00	FITTING	1
077	46.60251.00	FITTING	1
078	48.10943.00	RACOR	1
079	46.10401.00	FITTING	2
080	46.10402.00	COUPLING	1
081	48.10313.00	FITTING	3
082	66.10875.00	FITTING MB/M MB 1/4" BSP-MM M14	1
083	17.10169.00		1
084	46.58112.00		1
085	66.10869.00	C90TO/M MB M10X1-MM M12X1.5L6	1
086	30.10302.00	GASKET 1	2
087	46.10845.00	CLAMP SAE6000 1	2
088	66.10801.00	FITTING	2
089	66.10802.00	RUBBER SEAL REC. POLIU.1 1/4"	2
090	48.10322.00	FITTING C90M/TL M45X2	1
091	33.10201.00	C90M/TL CONNECTOR M12X1, 5	5
100	46.60233.91	FITTING	1

101	66.10805.00	FITTING C90MO/M MB3/4"BSP-M36x2	1
102	12.10301.00	FITTING	1
103	66.10807.00	FLANGE RGB-REC-D35MM-M22Junta	1
104	48.10423.00	FITTING	1
105	48.10326.00	FITTING	1
106	64.10227.00	FITTING	1
107	48.10223.00	FITTING	1
108	64.10226.00	FITTING	1
109	46.10911.00	FITTING	1
110	66.10803.00	FITTING M/TL MM M26X1.5 (L18) TL	1
111	20.10550.00	FITTING	1
112	48.10437.00	FITTING	2
113	46.10825.00	FITTING	2
114	70.10229.00	FITTING	4
115	39.05924.00	FITTING	1
116	48.10433.00	FITTING	1
117	48.10836.00	RACOR M/M MB 3/8 BSP - MM M18L	4

10. HYDRAULIC INSTALLATION

STANDARD HYDRAULIC DIAGRAM

CHASSIS: 93853

FIGURE	REFERENCE	DENOMINATION	AMOUNT
118	66.10800.00	RACOR	2
119	46.10450.00	FITTING	1
120	46.10849.00	FITTING	2
121	30.10335.00	FITTING	2
122	48.10109.00	FITTING	2
123	70.10258.00	FITTING	2
124	70.10255.00	FITTING	2
125	48.10764.00	FITTING	2
126	48.10934.00	FITTING	2
127	66.13134.00	FITTING	2
128	66.13135.00	FITTING	2
129	66.13136.00	FITTING	6
130	66.10891.00	FITTING	2
131	66.10892.00	FITTING	2
132	66.10893.00	FITTING	6
133	66.10894.00	FITTING	2
134	66.10895.00	FITTING	2

135	48.10858.00	FITTING	6
136	45.01423.00	GASKET	4
137	08.00316.00	METALLIC GASKET BUNA D1/2 G	4
138	08.00317.00	METALLIC GASKET BUNA D3/8	12
139	20.10440.00	FITTING	1
140	46.58181.00	FITTING	4
141	48.10320.00	RACOR FORT M/M/TL -M14X1,5	1
142	48.10351.00	FITTING M/M 1/8 BSP M12X1.5	2
143	46.58112.00		2
150	66.13151.00	TUBE	1
151	66.13152.00	TUBE	1
152	66.13153.00	TUBE	1
153	66.13154.00	TUBE	1
154	66.13155.00	TUBE	1
155	66.13156.00	TUBE	1
156	66.13157.00	TUBE	1
157	66.13158.00	TUBE	1
158	66.13159.00	TUBE	1
159	66.13160.00	TUBE	1

10. HYDRAULIC INSTALLATION

STANDARD HYDRAULIC DIAGRAM

CHASSIS: 93853

FIGURE	REFERENCE	DENOMINATION	AMOUNT
160	66.13161.00	TUBE	1
161	66.13162.00	TUBE	1
162	66.13163.00	TUBE	1
163	66.13164.00	TUBE	1
164	66.13165.00	TUBE	1
165	66.13166.00	TUBE	1
166	66.13167.00	TUBE	1
167	66.13168.00	TUBE	1
168	66.13169.00	TUBE	2
169	66.13170.00	TUBE	2
170	66.13171.00	TUBE	1
171	66.13172.00	TUBE	1
172	66.13173.00	TUBE	2

COMMENTS

pm.00283

11. ELECTRIC INSTALLATION ACOUSTIC WARNING

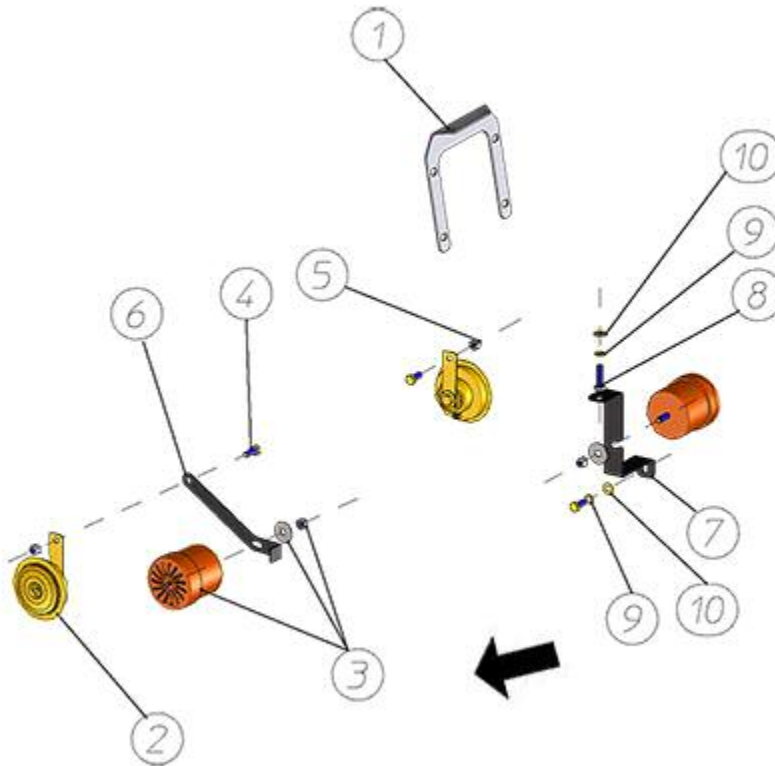

FIGURE	REFERENCE	DENOMINATION	AMOUNT
001	66.11146.00	SHEET	1
002	70.11309.00	HORN	2
003	02.14110.03	HORN	2
004	603.08020.86	SCREW DIN933 M8x20	3
005	711.08000.66	NUT DIN982 M8	2
006	66.04139.00	SHEET	1
007	66.04241.00	SHEET	1
008	603.08030.86	SCREW DIN933 M8X30	1
009	104.08000.00	WASHER DIN7980 D8	2
010	101.08000.66	WASHER DIN125 D8	2

10. HYDRAULIC INSTALLATION

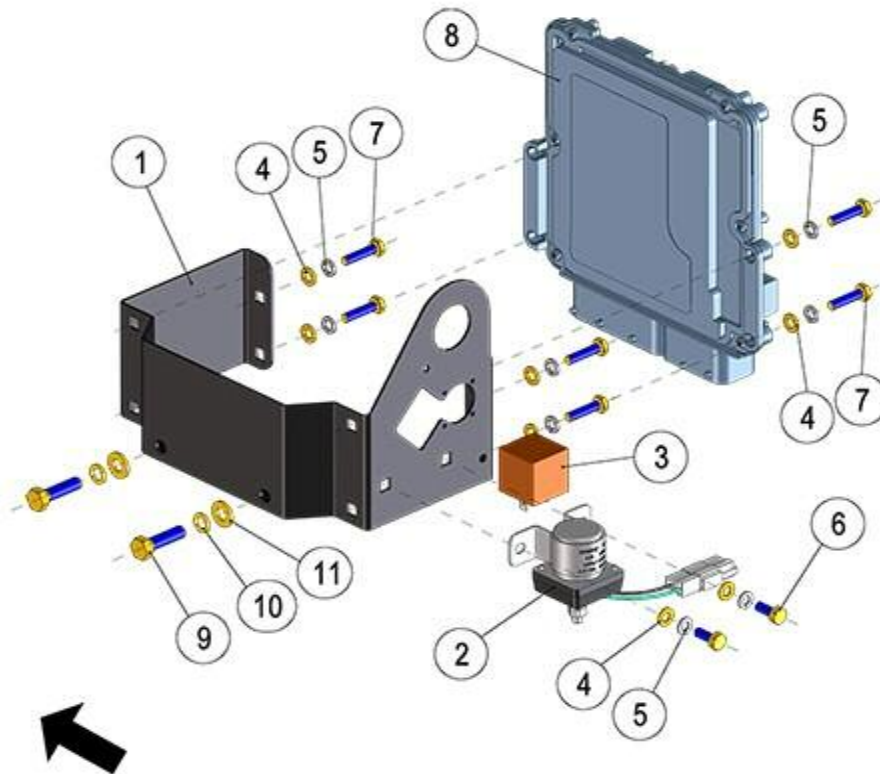

FIGURE	REFERENCE	DENOMINATION	AMOUNT
001	66.11110.00	SUPPORT FIXATION ECU	1
002	64.11041.00	RELAY 12V 100A	1
003	43.01530.02	RELAY 40 AMP. 5 CONTAC. 6.3MM	1
004	101.06000.66	WASHER DIN125 D6	10
005	104.06000.00	WASHER DIN7980 D6	10
006	603.06015.86	SCREW DIN933 M6x15	2
007	603.06025.86	SCREW DIN933 M6x25	8
008	66.11120.00	ECU BRR RC10-10/31	1
009	603.08030.86	SCREW DIN933 M8X30	2
010	104.08000.00	WASHER DIN7980 D8	2
011	101.08000.66	WASHER DIN125 D8	2

11. ELECTRIC INSTALLATION

BATTERY

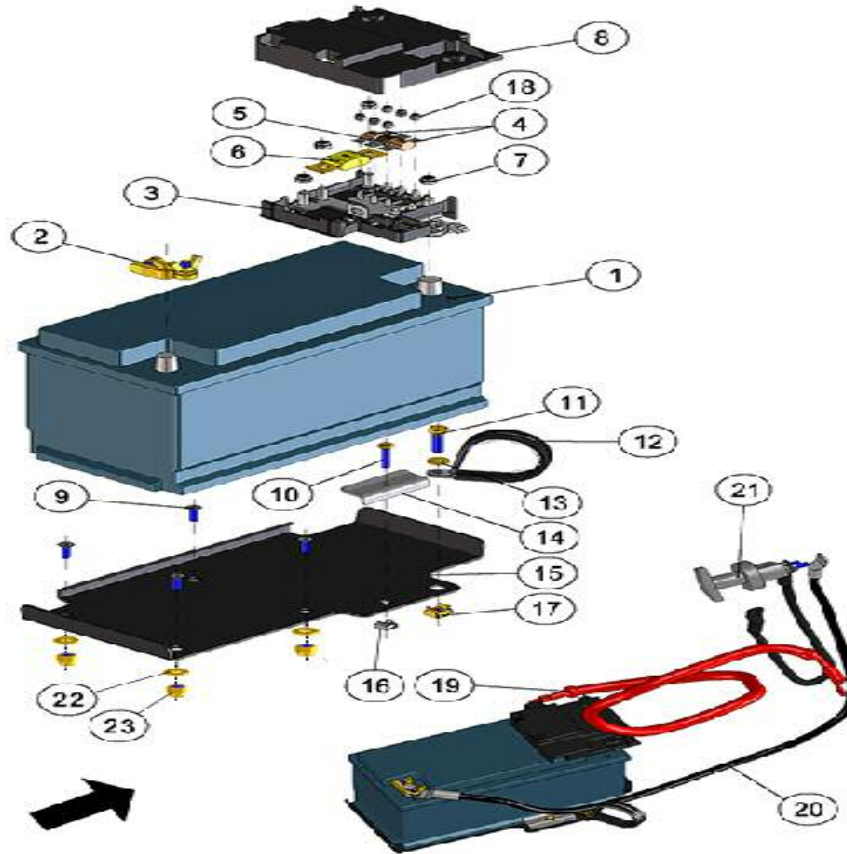

FIGURE	REFERENCE	DENOMINATION	AMOUNT
001	46.11100.00	BATTERY	1
002	20.11007.01	NEGATIVE BATTERY CONNECTOR	1
003	20.11009.00	BATTERY FUSE BOX	1
004	13.11109.00	30A FUSE	2
005	20.11011.02	FUSE 70A	1
006	66.11114.00	FUSE 100A GENERAL PROTECTOR	1
007	711.08000.66	NUT DIN982 M8	4
008	20.11014.00	BATTERY FUSEBOX COVER	1
009	618.06040.86	FLAT HEAD SOCKET CAP SCREW DIN7991 M6x40	4
010	603.06030.86	SCREW DIN933 M6x30	1
011	603.08030.86	SCREW DIN933 M8x30	1
012	830.06008.00	CLAMP D60x8	1
013	101.08000.66	WASHER DIN125 D8	1
014	20.11101.00	FIXATION SUPPORT 2X10X70	1
015	66.11800.00	BATTERY SUPPORT	1
016	726.06003.66	CAGED NUT M6x3	1

017	726.08003.66	NUT M8x3	1
018	711.05000.66	NUT DIN982 M5	6

11. ELECTRIC INSTALLATION BATTERY

FIGURE	REFERENCE	DENOMINATION	AMOUNT
019	66.11200.00	WIRE 50X1000MM M8-M8 90	1
020	66.11203.00	ELECTRIC WIRE 50X1350MM M10-M8	1
021	63.11111.00	NEGATIVE BATTERY DISCONNECTOR	1
022	101.06000.66	WASHER DIN125 D6	4
023	711.06000.66	NUT DIN982 M6	4

11. ELECTRIC INSTALLATION

ELECTRIC SENSORS

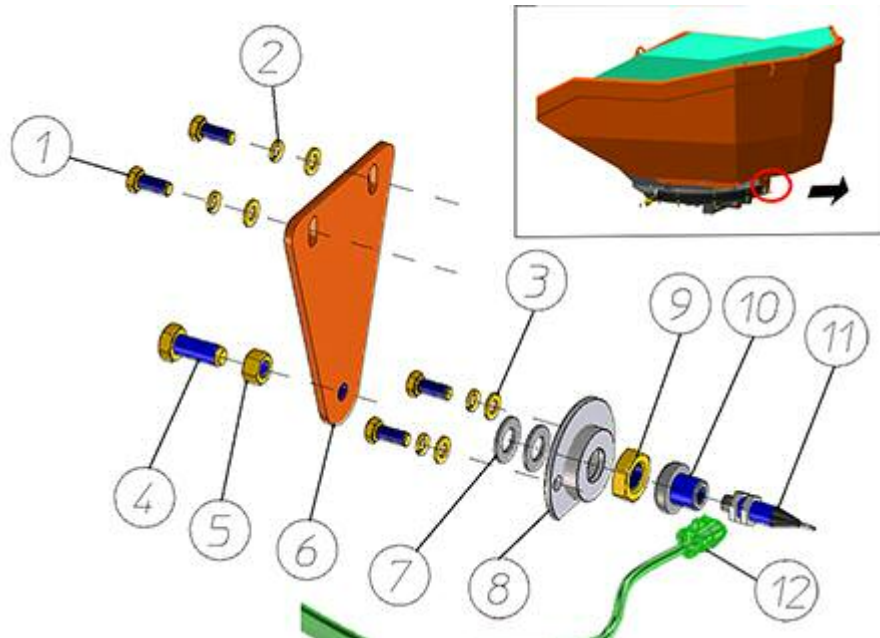

FIGURE	REFERENCE	DENOMINATION	AMOUNT
001	603.08020.86	SCREW DIN933 M8x20	4
002	104.08000.00	WASHER DIN7980 D8	4
003	101.08000.66	WASHER DIN125 D8	4
004	603.12030.87	SCREW DIN933 M12x30	1
005	701.12000.67	NUT DIN934 M12x1,75	1
006	66.09113.00	SUPPORT	1
007	101.14000.66	WASHER DIN125 D14	2
008	66.04142.00	SUPPORT	1
009	709.18000.67	NUT DIN936 M18x1, 5	1
010	46.09916.00	PROT. CIL. POSITION SENSOR	1
011	46.11053.02	SENSOR IND.M12 NO PNP	1
012	66.11028.00	FRONT CHASSIS WIRING HARNESS	1

11. ELECTRIC INSTALLATION WIRING HARNESS (PART 1)

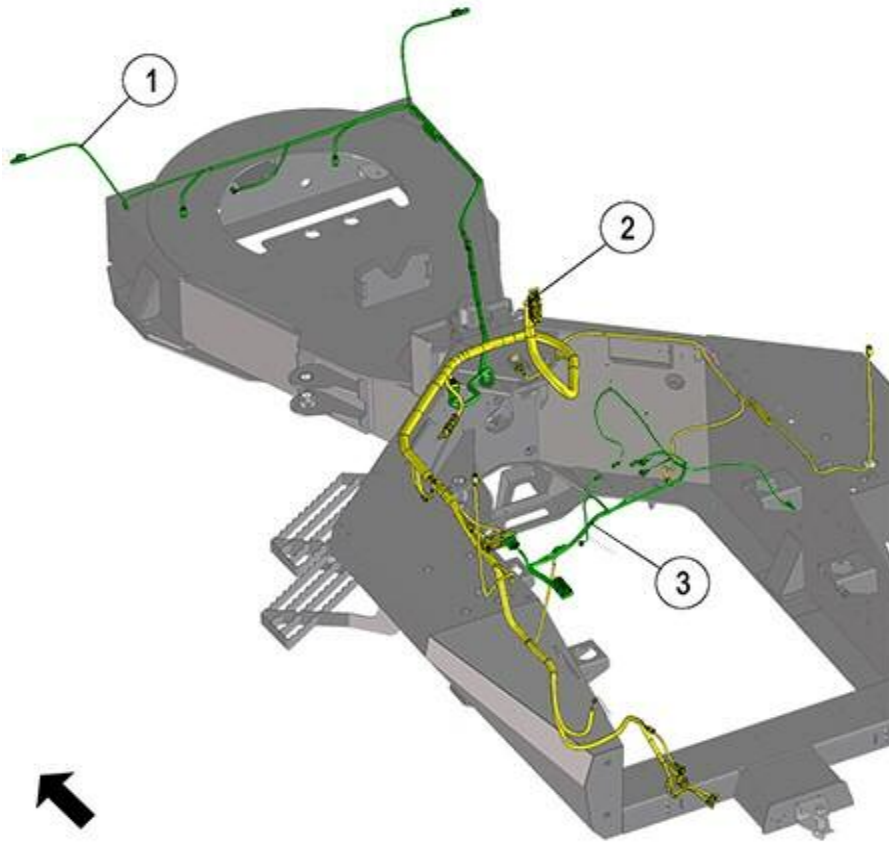

FIGURE	REFERENCE	DENOMINATION	AMOUNT
002	66.11014.00	REAR CHASSIS WIRING HARNESS	1
003	66.11003.00	WIRE HIYDR. TRANS. BRR	1

11. ELECTRIC INSTALLATION

ENGINE WIRING HARNESS

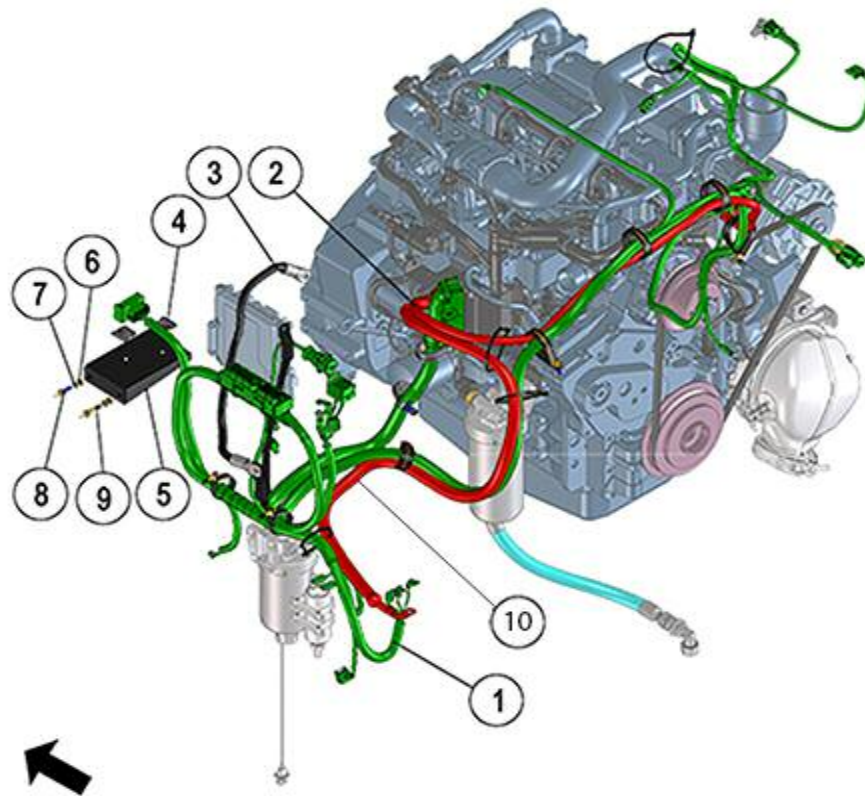

FIGURE	REFERENCE	DENOMINATION	AMOUNT
001	66.11013.00	WIRING HARNESS ENGINE ECU	1
002	66.11201.00	WIRE 25X1000MM M10-M8	1
003	64.11006.00	BATTERY NEGATIVE WIRE	1
004	840.00004.00	ELECTRIC SUPPORT DELPHI FCI	2
005	66.11121.00	ELECTRIC CONNECTORS SUPPORT (9005)	1
006	101.06000.66	WASHER DIN125 D6	2
007	104.06000.00	WASHER DIN7980 D6	2
008	603.06020.86	SCREW DIN933 M6x20	1
009	604.06030.86	SCREW DIN931	1
010	66.11200.00	WIRE 50X1000MM M8-M8 90	1

11. ELECTRIC INSTALLATION

DASHBOARD (1)

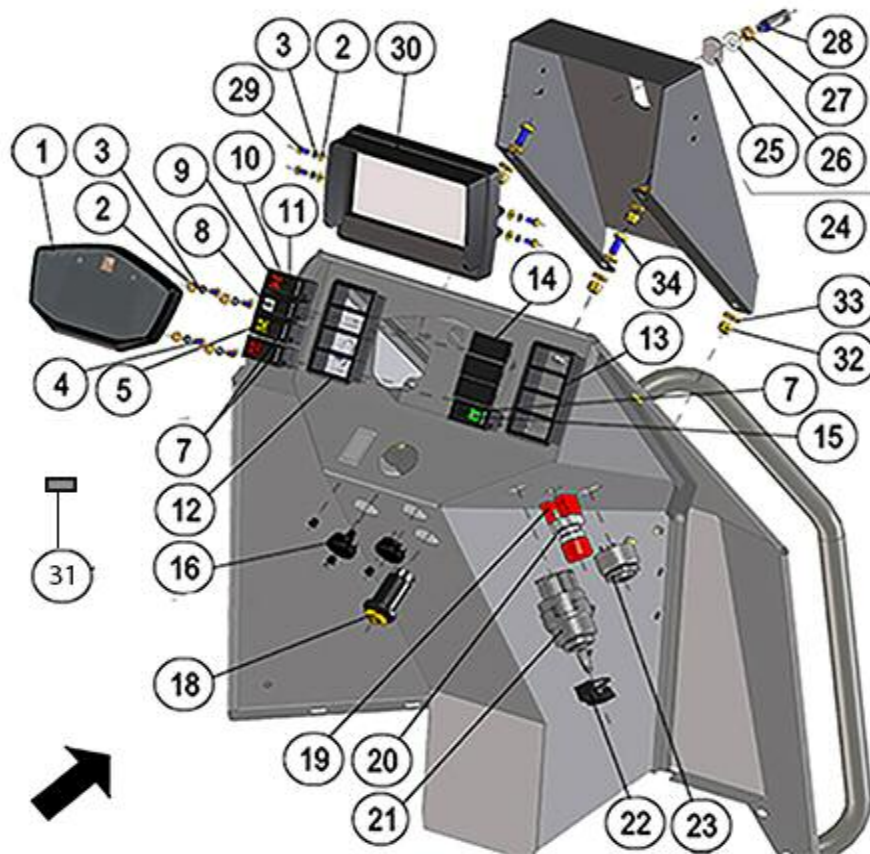

FIGURE	REFERENCE	DENOMINATION	AMOUNT
001	66.11104.00	DISPLAY PROGRAMMABLE LCD 4" COL	1
002	101.05000.66	WASHER DIN125 D5	8
003	104.05000.00	WASHER DIN7980 D5	8
004	630.05015.96	SCREW ISO7380 M5x15	4
005	66.11140.00	COVER	1
007	30.11012.00	SWITCH OFF-ON 1P SWF	2
008	66.11116.00	COVER DIAGNOSIS ENGINE SWF 270°	1
009	66.11103.00	COVER PARKING SWF 270°	1
010	30.11008.00	SWITCH ON-ON 1P SWF	1
011	66.11142.00	BUTTON OFF/ON	1
012	66.11112.00	BOX	4
013	66.11113.00	BOX	4
014	12.11024.00	SWITCH CAP	4
015	66.11115.00	HORN COVER	1
016	13.08035.00	COUNTERWEIGHT CAP	1
018	IM.20013.00	SWITCH	1

019	48.11590.01	NC CONTACTOR FOR EMERGENCY STOP	3
020	48.11590.00	SWITCH EMERGENCY 1 CONTONTACTOR NC	1

11. ELECTRIC INSTALLATION DASHBOARD (1)

FIGURE	REFERENCE	DENOMINATION	AMOUNT
021	32.08172.00	MAIN SWITCH WITH KEY ASSEMBLY	1
022	12.11034.00	PROTECTOR CONMUT. ARRANQUE	1
023	12.11033.00	HORN KPE650	1
024	64.04454.00	FIXATION SUPPORT	1
025	64.04451.00	AXLE	1
026	116.01000.00	WASHER DIN 125 A D10	1
027	701.10000.66	NUT DIN934 M10x1.5	1
028	64.04453.00	AXLE	1
029	603.05010.86	SCREW DIN933 M5x10	4
030	64.11051.00	DISPLAY COLOR TFT LCD 7	1
031	66.11157.00	CONNECTOR	1
032	711.08000.66	NUT DIN982 M8	4
033	101.08000.66	WASHER DIN125 D8	8
034	603.08020.86	SCREW DIN933 M8x20	4

11. ELECTRIC INSTALLATION

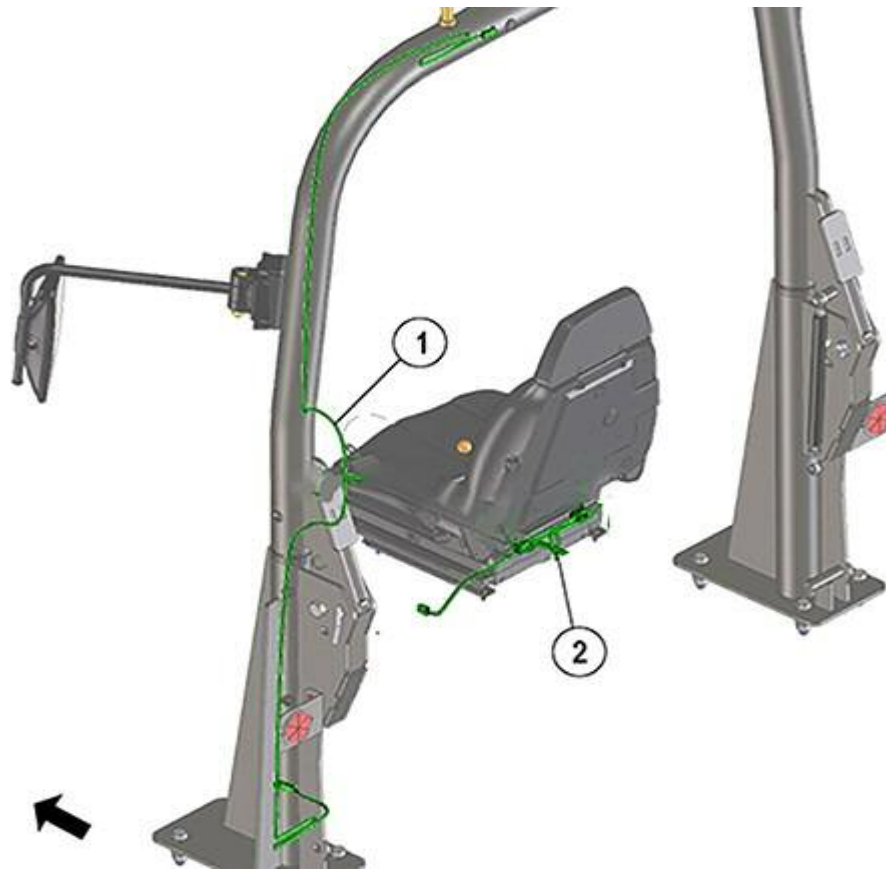

FIGURE	REFERENCE	DENOMINATION	AMOUNT
001	66.11011.00	EXTENSION WIRE 3150 2V 2V	1
002	67.11006.00	SEAT LENGTH ELEC. INSTAL.	1

11. ELECTRIC INSTALLATION

DASHBOARD WIRING

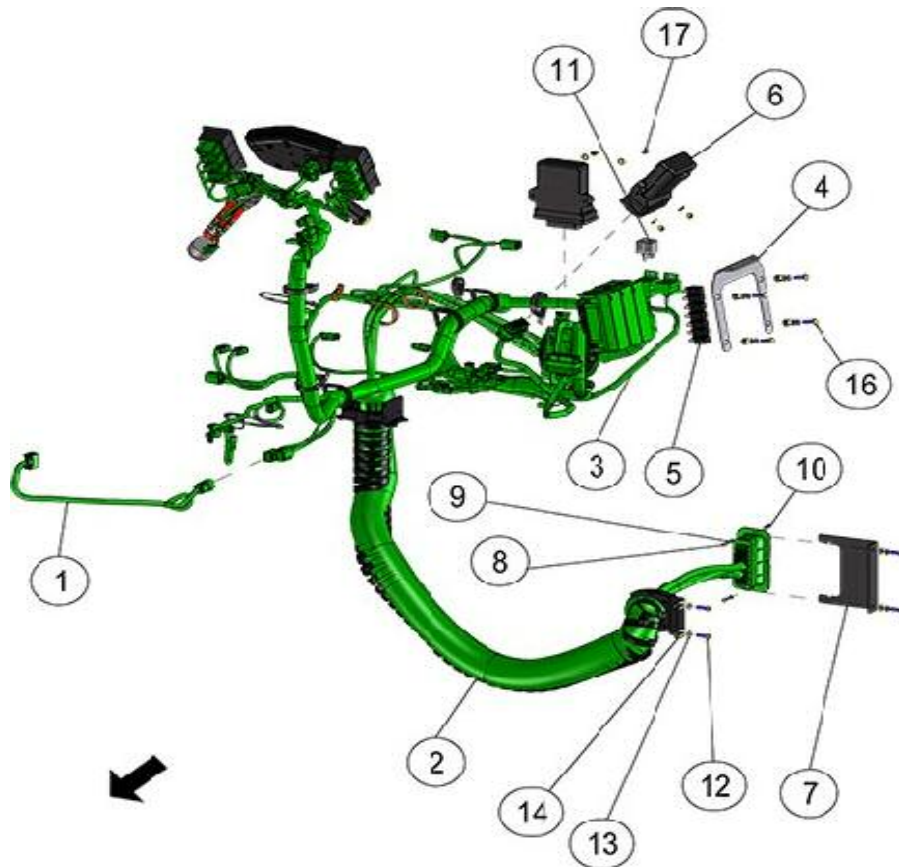

FIGURE	REFERENCE	DENOMINATION	AMOUNT
001	66.11018.00	ACCELERATOR CABLE	1
002	66.11009.00	WIRING PEDAL	1
003	66.11026.00	DASHBOARD WIRING	1
004	66.11146.00	SHEET	1
005	IM.20026.03	MICRO RELAY WITH DIODE	7
006	66.11107.00	ECU MACHINE FUNC.	2
007	66.08172.00	SHEET	1
008	630.04015.97	SCREW M4x15 ISO7380	2
009	101.04000.66	WASHER DIN125 D4	4
010	711.04000.66	NUT	2
011	48.11170.00	RELAY 70A UNSUPPORTED WITH DIODE	1
012	630.06020.87	SCREW ISO 7380 M6x20	4
013	101.06000.67	WASHER DIN125 D6	12
014	727.06004.86	CAGED NUT M6x4	6
015	104.06000.00	WASHER DIN7980 D6	6
016	603.06020.86	SCREW DIN933 M6x20	4



017 711.06000.66

NUT DIN982 M6

4

12. FINISHES

STANDARD STICKER (1)

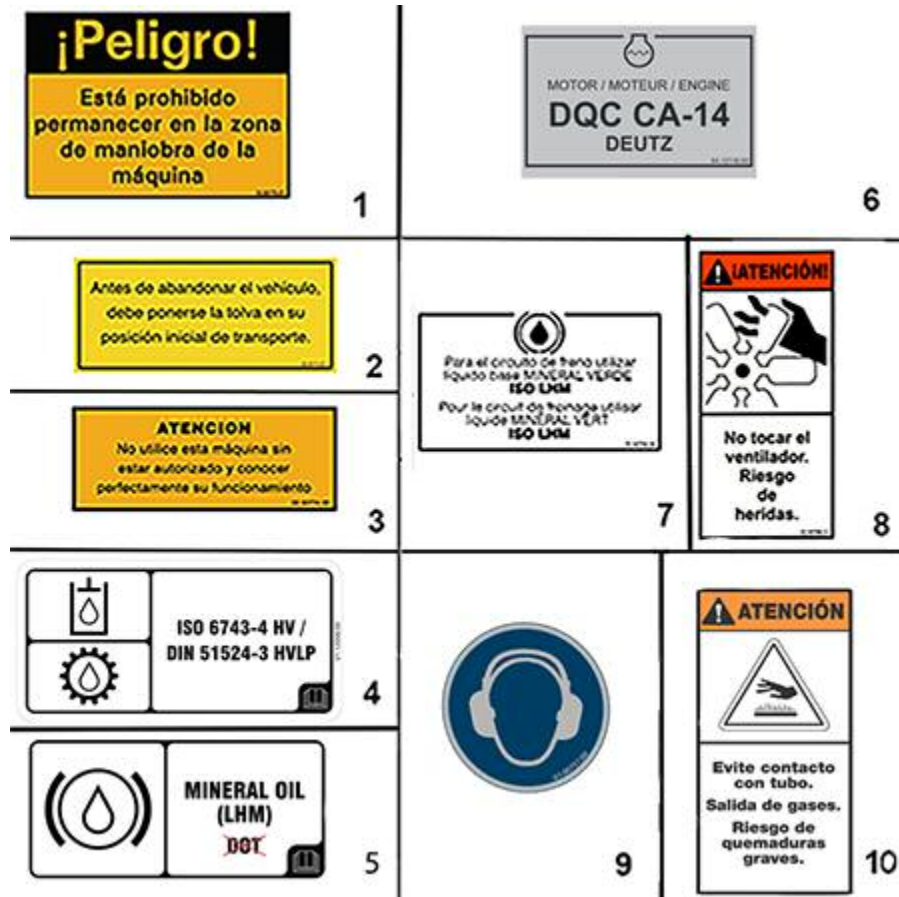

FIGURE	REFERENCE	DENOMINATION	AMOUNT
001	14.00775.01	PLATE AD. INDI	2
002	02.00773.01	PLATE AD. INDI	1
003	02.00774.00	PLATE AD. INDI	1
004	01.12006.00		1
005	01.12501.00	BRAKE ADHESIVE PLATE	1
006	64.12118.00	COOLANT STICKER DQC CA14	1
007	55.00780.00	PLATE AD. INDI	1
008	02.00766.01	ADH. PLATE IND. 40x80, SPANISH	1
009	01.00757.00	PLATE AD. INDI	1
010	02.00764.00	PLATE AD. INDI	1

12. FINISHES

STANDARD STICKER (2)

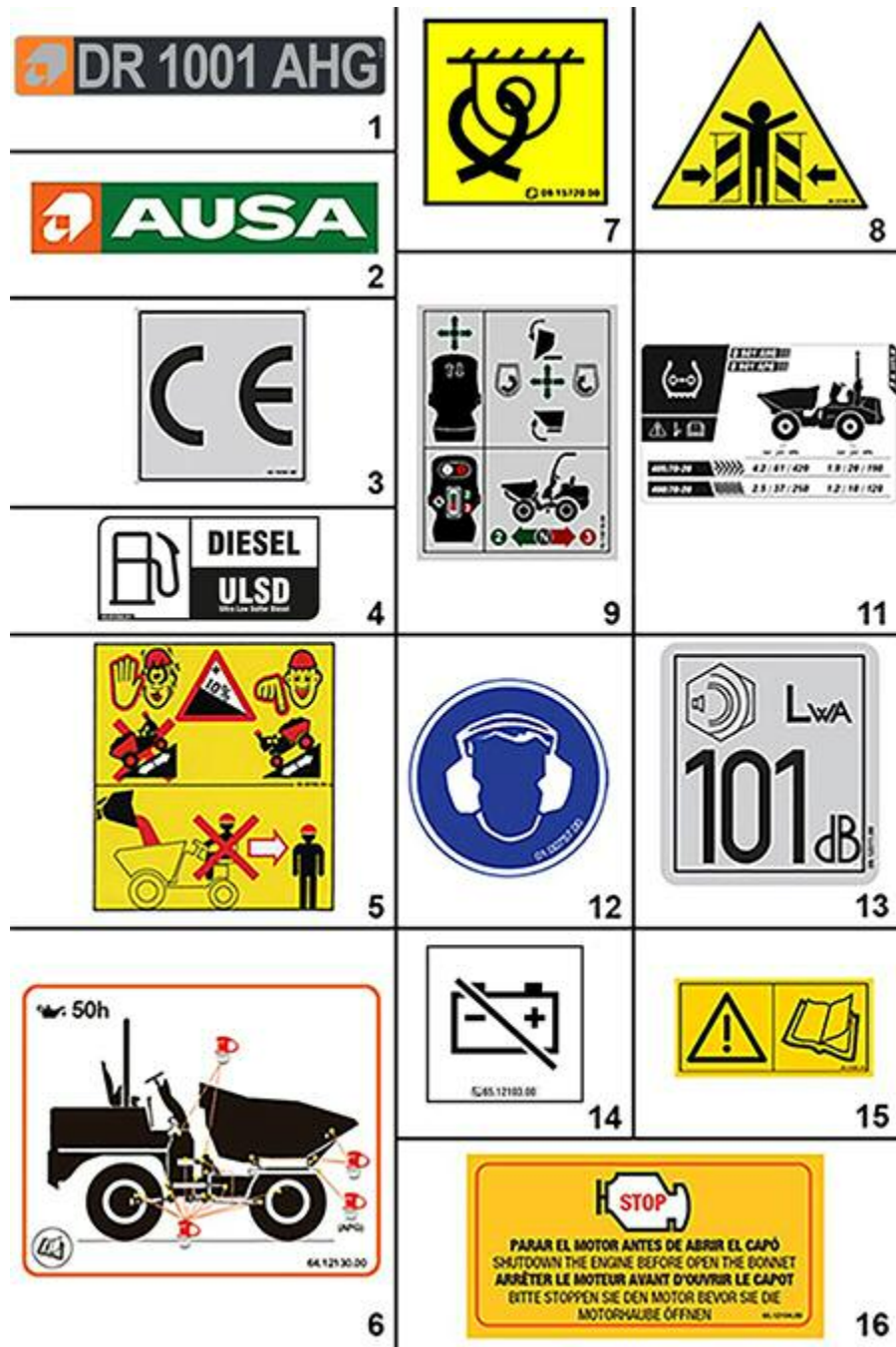

FIGURE	REFERENCE	DENOMINATION	AMOUNT
001	66.12600.00	MODEL STICKER DR 1001 AHG	2
002	13.12136.02	ADHESIVE, AUSA 720x147	2
003	45.19101.00	PLATE AD. INDI	2
004	43.01356.01	ADH. PLATE IND. DIESEL ULSD 90	1
005	09.00769.00	PLATE AD. INDI	1
006	64.12130.00	INDI. PLATE GREASING POINTS	1



007	09.15720.00	PLATE AD. INDI	4
008	60.22350.00	PLATE AD. INDI	2
009	70.12018.00	ADHESIVE CONTROLS LEVER	1
011	66.12070.00	WHEELS PRESSURE STICKER	1
012	01.00757.00	PLATE AD. INDI	1
013	09.12011.00	ADHESIVE	1
014	65.12103.00	STICKER DISCONNECT	1
015	48.12026.00	STICKER BOOK INSTRUCTIONS	3
016	65.12104.00	STICKER ENGINE SHUTDOWN	2

12. FINISHES

STANDARD STICKER (3)



FIGURE	REFERENCE	DENOMINATION	AMOUNT
001	70.12120.00	STICKER LIFT POINT	2
002	64.12119.00	STICKER OIL DQC IV 10 LA D	1
003	65.12131.00	STICKER 6000KG MAX	1
004	65.12102.00	STICKER ARCH FOLDED POSITION	1
005	64.12124.00	DO NOT DISCONNECT STICKER	1

12. FINISHES

TOOLS BAG



FIGURE	REFERENCE	DENOMINATION	AMOUNT
001	01.00036.02	TOOLS-BAG	1

13. ACCESSORIES CLOSED CABIN

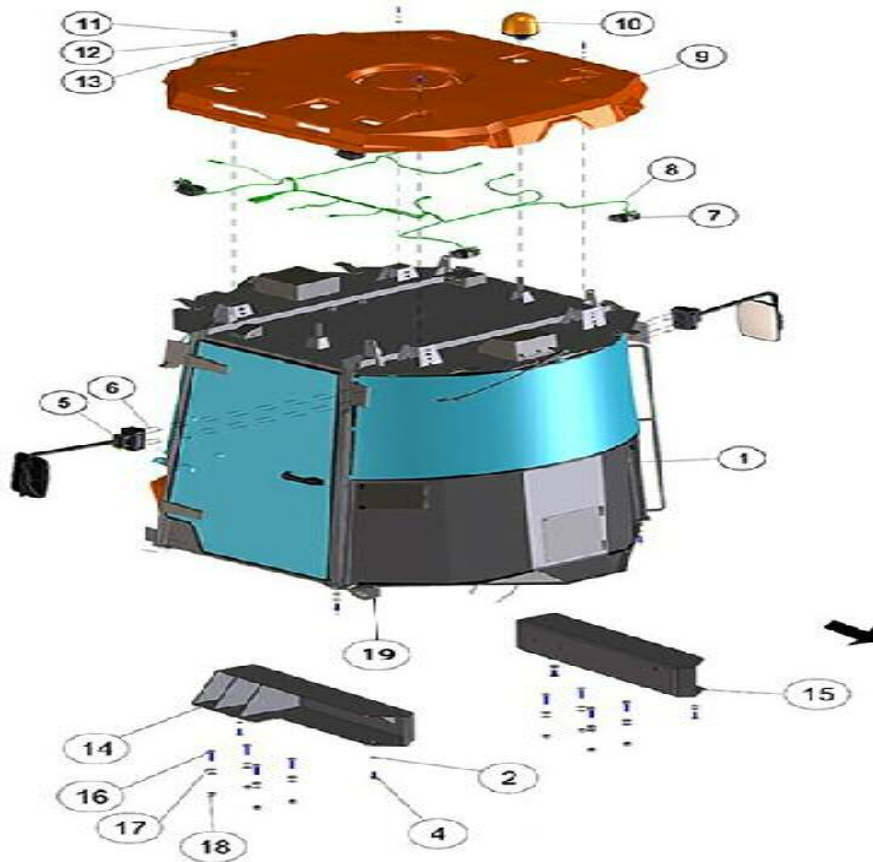

FIGURE	REFERENCE	DENOMINATION	AMOUNT
001	66.08220.00	CLOSED CABIN	1
001	66.08220.00	CLOSED CABIN	1
002	101.16000.66	WASHER DIN125 D16	4
002	101.16000.66	WASHER DIN125 D16	4
004	618.16060.86	FLAT HEAD SOCKET CAP SCREW DIN7991 M16x60	2
004	618.16060.86	FLAT HEAD SOCKET CAP SCREW DIN7991 M16x60	2
005	66.08251.00	REAR-VIEW MIRROR	2
005	66.08251.00	REAR-VIEW MIRROR	2
006	618.08020.86	SCREW DIN7991 M8x20	8
006	618.08020.86	SCREW DIN7991 M8x20	8
007	24.11143.00	REAR LAMP/WORK LAMP leds	4
007	24.11143.00	REAR LAMP/WORK LAMP leds	4
008	66.11023.00	ROOF WIRING	1
008	66.11023.00	ROOF WIRING	1
009	66.08227.00	CASE CABIN	1
009	66.08227.00	CASE CABIN	1

010	01.00912.00	BEACON	1
010	01.00912.00	BEACON	1

13. ACCESSORIES

CLOSED CABIN

FIGURE	REFERENCE	DENOMINATION	AMOUNT
011	630.12025.87	SCREW ISO7380 M12X25	4
011	630.12025.87	SCREW ISO7380 M12X25	4
012	105.12000.66	WASHER DIN7980 D12	4
012	105.12000.66	WASHER DIN7980 D12	4
013	101.12000.66	WASHER DIN125 D12	4
013	101.12000.66	WASHER DIN125 D12	4
014	66.08092.00	SUPPORT	1
014	66.08092.00	SUPPORT	1
015	66.08091.00	SUPPORT	1
015	66.08091.00	SUPPORT	1
016	604.18070.86	SCREW DIN931	8
016	604.18070.86	SCREW DIN931	8
017	101.18000.66	BEARING DIN125 D18	16
017	101.18000.66	BEARING DIN125 D18	16
018	711.18000.66	NUT DIN982 M18	8
018	711.18000.66	NUT DIN982 M18	8
019	66.04415.00	CABIN REINFORCEMENT SUPPORT	2
019	66.04415.00	CABIN REINFORCEMENT SUPPORT	2

13. ACCESSORIES

CLOSED CABIN (1)

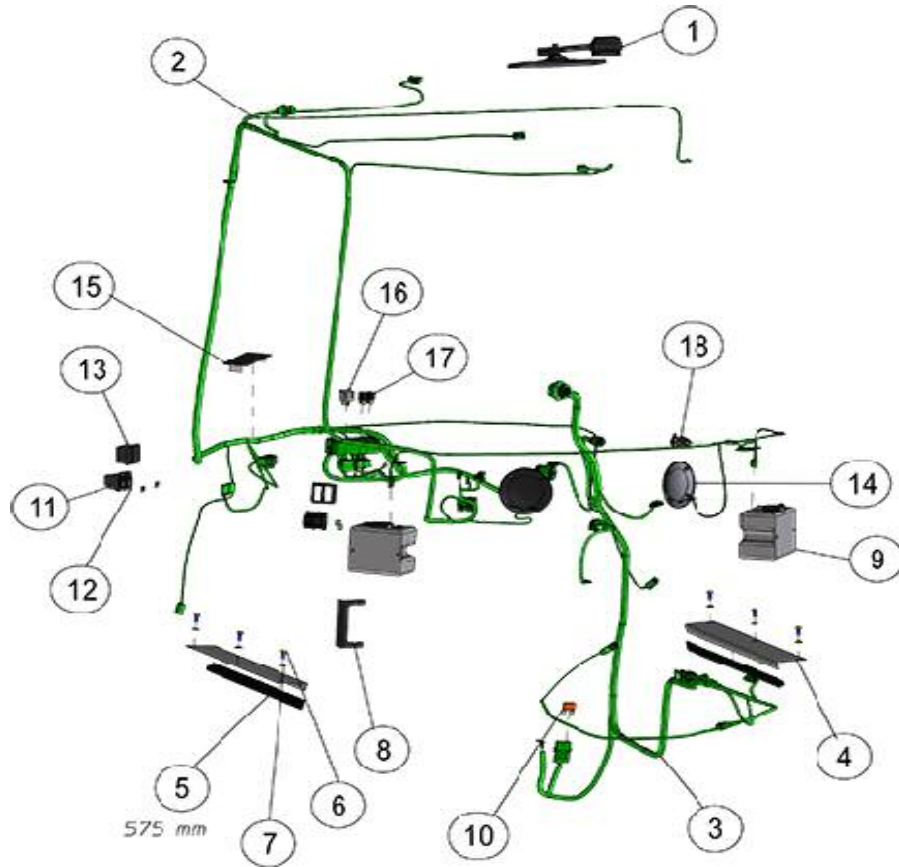

FIGURE	REFERENCE	DENOMINATION	AMOUNT
001	66.08351.00	REAR-VIEW MIRROR	1
001	66.08351.00	REAR-VIEW MIRROR	1
002	66.11022.00	CABIN WIRING HARNESS	1
002	66.11022.00	CABIN WIRING HARNESS	1
003	66.11021.00	CHASSIS WIRING HARNESS	1
003	66.11021.00	CHASSIS WIRING HARNESS	1
004	66.08291.00	SHEET	2
004	66.08291.00	SHEET	2
005	472.00410.00	RUBBER PROFILE 22X22	2
005	472.00410.00	RUBBER PROFILE 22X22	2
006	630.08020.96	SCREW ISO7380	6
006	630.08020.96	SCREW ISO7380	6
007	101.08000.66	WASHER DIN125 D8	6
007	101.08000.66	WASHER DIN125 D8	6
008	66.08171.00	SUPPORT	1
008	66.08171.00	SUPPORT	1

009	46.08621.00	SCREEN WIPER PUMP TANK	2
009	46.08621.00	SCREEN WIPER PUMP TANK	2

13. ACCESSORIES

CLOSED CABIN (1)

FIGURE	REFERENCE	DENOMINATION	AMOUNT
010	32.11027.00	BIG SIZE FUSE 40A	1
010	32.11027.00	BIG SIZE FUSE 40A	1
011	30.11012.00	SWITCH OFF-0N 1P SWF	2
011	30.11012.00	SWITCH OFF-0N 1P SWF	2
012	66.11149.00	SWITCH	2
012	66.11149.00	SWITCH	2
013	66.11112.00	BOX	4
013	66.11112.00	BOX	4
014	48.08325.00	LID. SPEAKER	2
014	48.08325.00	LID. SPEAKER	2
015	46.08589.00	RADIO LODGING COVER	1
015	46.08589.00	RADIO LODGING COVER	1
016	48.11170.00	RELAY 70A UNSUPPORTED WITH DIODE	1
016	48.11170.00	RELAY 70A UNSUPPORTED WITH DIODE	1
017	IM.20026.03	MICRO RELAY WITH DIODE	2
017	IM.20026.03	MICRO RELAY WITH DIODE	2
018	13.11196.00	MAKING HELLA PLUG 12V	1
018	13.11196.00	MAKING HELLA PLUG 12V	1

13. ACCESSORIES

CLOSED CABIN (2)

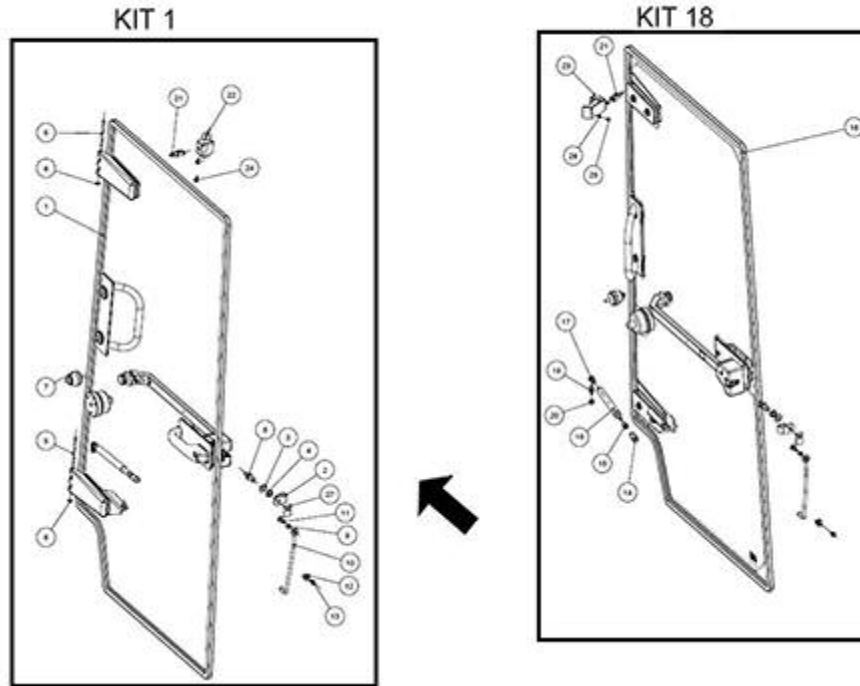

FIGURE	REFERENCE	DENOMINATION	AMOUNT
0 KIT 1	66.82250.00	DOOR SET	1
0 KIT 18	66.82240.00	DOOR SET	1
001	66.08224.00	GLASS	1
001	66.08224.00	GLASS	1
001	66.08224.00	GLASS	1
001	66.08224.00	GLASS	1
001	66.08224.00	GLASS	1
001	66.08224.00	GLASS	1
001	66.08224.00	GLASS	1
002	MACERR0033	LOCK	2
002	MACERR0033	LOCK	2
002	MACERR0033	LOCK	2
002	MACERR0033	LOCK	2
003	MAARAN0014	WASHER	2
003	MAARAN0014	WASHER	2
003	MAARAN0014	WASHER	2
003	MAARAN0014	WASHER	2
004	MAARAN0016	WASHER	2
004	MAARAN0016	WASHER	2
004	MAARAN0016	WASHER	2

004	MAARAN0016	WASHER	2
005	MATORN5126	PIN	4
005	MATORN5126	PIN	4
005	MATORN5126	PIN	4
005	MATORN5126	PIN	4
006	MAARAN0059	WASHER	4
006	MAARAN0059	WASHER	4
006	MAARAN0059	WASHER	4
006	MAARAN0059	WASHER	4
007	MACERR0061	LOCKING DOOR KIT	2
007	MACERR0061	LOCKING DOOR KIT	2
007	MACERR0061	LOCKING DOOR KIT	2
007	MACERR0061	LOCKING DOOR KIT	2
008	MACERR0071	BOLT	2
008	MACERR0071	BOLT	2
008	MACERR0071	BOLT	2
008	MACERR0071	BOLT	2

13. ACCESSORIES

CLOSED CABIN (2)

FIGURE	REFERENCE	DENOMINATION	AMOUNT
009	MATORN5260	BUSH	2
009	MATORN5260	BUSH	2
009	MATORN5260	BUSH	2
009	MATORN5260	BUSH	2
010	MACOTP0154	BLOCK	2
010	MACOTP0154	BLOCK	2
010	MACOTP0154	BLOCK	2
010	MACOTP0154	BLOCK	2
011	MATORN0196	SCREW	2
011	MATORN0196	SCREW	2
011	MATORN0196	SCREW	2
011	MATORN0196	SCREW	2
012	MAIPLA0117	SHEET	2
012	MAIPLA0117	SHEET	2
012	MAIPLA0117	SHEET	2
012	MAIPLA0117	SHEET	2
013	MATORN0014	SCREW	2

013	MATORN0014	SCREW	2
013	MATORN0014	SCREW	2
013	MATORN0014	SCREW	2
014	MAAMOR0027	BALL JOINTS	2
014	MAAMOR0027	BALL JOINTS	2
014	MAAMOR0027	BALL JOINTS	2
014	MAAMOR0027	BALL JOINTS	2
015	MATORN0471	SCREW	2
015	MATORN0471	SCREW	2
015	MATORN0471	SCREW	2
015	MATORN0471	SCREW	2
016	66.08256.00	SHOCK ABSORBER	2
016	66.08256.00	SHOCK ABSORBER	2
016	66.08256.00	SHOCK ABSORBER	2
016	66.08256.00	SHOCK ABSORBER	2
017	MAAMOR0007	SHOCK ABSORBER	2
017	MAAMOR0007	SHOCK ABSORBER	2
017	MAAMOR0007	SHOCK ABSORBER	2
017	MAAMOR0007	SHOCK ABSORBER	2

13. ACCESSORIES

CLOSED CABIN (2)

FIGURE	REFERENCE	DENOMINATION	AMOUNT
018	66.08225.00	GLASS	1
018	66.08225.00	GLASS	1
019	MATORN5003	BALL JOINTS	2
019	MATORN5003	BALL JOINTS	2
019	MATORN5003	BALL JOINTS	2
019	MATORN5003	BALL JOINTS	2
020	LUTUER0011	NUT	2
020	LUTUER0011	NUT	2
020	LUTUER0011	NUT	2
020	LUTUER0011	NUT	2
021	MA1.51234	SWITCH	2
021	MA1.51234	SWITCH	2
021	MA1.51234	SWITCH	2
021	MA1.51234	SWITCH	2
022	MACHAP10093	SHEET	1

022	MACHAP10093	SHEET	1
022	MACHAP10093	SHEET	1
022	MACHAP10093	SHEET	1
023	MACHAP10098	SHEET	1
023	MACHAP10098	SHEET	1
023	MACHAP10098	SHEET	1
023	MACHAP10098	SHEET	1
024	MATORN0273	SCREW	2
024	MATORN0273	SCREW	2
024	MATORN0273	SCREW	2
024	MATORN0273	SCREW	2
025	MATUER0002	NUT	2
025	MATUER0002	NUT	2
025	MATUER0002	NUT	2
025	MATUER0002	NUT	2
026	MAARAN0135	WASHER	2
026	MAARAN0135	WASHER	2
026	MAARAN0135	WASHER	2
026	MAARAN0135	WASHER	2
027	MACHAP6904	PIN	2
027	MACHAP6904	PIN	2

13. ACCESSORIES

CLOSED CABIN (2)

FIGURE	REFERENCE	DENOMINATION	AMOUNT
027	MACHAP6904	PIN	2
027	MACHAP6904	PIN	2

13. ACCESSORIES

CLOSED CABIN (3)



FIGURE	REFERENCE	DENOMINATION	AMOUNT
001	66.08222.00	REAR GLASS	1
001	66.08222.00	REAR GLASS	1
002	MAPERC0260	GASKET	1
002	MAPERC0260	GASKET	1
003	MACHAP9918	SHEET	1
003	MACHAP9918	SHEET	1
004	MACSOL0104	SHEET	1
004	MACSOL0104	SHEET	1
005	MACHAP10077	SHEET	1
005	MACHAP10077	SHEET	1
006	MACSOL0094	COVER	1
006	MACSOL0094	COVER	1
007	MACSOL0095	COVER	1
007	MACSOL0095	COVER	1
008	MACSOL0097	COVER	1
008	MACSOL0097	COVER	1
009	MAIPLA0023	NUT	4
009	MAIPLA0023	NUT	4
010	MAARAN0008	WASHER	18

010	MAARAN0008	WASHER	18
011	MATUER0005	NUT	16
011	MATUER0005	NUT	16
012	MAIPLA0047	CAP	9
012	MAIPLA0047	CAP	9
013	MATORN0177	SCREW	9
013	MATORN0177	SCREW	9
014	MATORN0210	SCREW	7
014	MATORN0210	SCREW	7
015	MATORN0273	SCREW	8
015	MATORN0273	SCREW	8
016	MAIPLA0218	KNOB	2
016	MAIPLA0218	KNOB	2
017	46.08621.00	SCREEN WIPER PUMP TANK	2
017	46.08621.00	SCREEN WIPER PUMP TANK	2
018	MAPARA0008	SUN VISOR	1
018	MAPARA0008	SUN VISOR	1

13. ACCESSORIES

CLOSED CABIN (3)

FIGURE	REFERENCE	DENOMINATION	AMOUNT
019	MATORN0407	SCREW	2
019	MATORN0407	SCREW	2
020	MALUNA1332	RIGHT LOWER GLASS	4
020	MALUNA1332	RIGHT LOWER GLASS	4
021	MAARAN0072	WASHER	16
021	MAARAN0072	WASHER	16
022	MAIPLA0280	NUT	16
022	MAIPLA0280	NUT	16
023	MAPERCO0331	GASKET	4
023	MAPERCO0331	GASKET	4
024	MAMATT5182	ADHESIVE STRIP	1
024	MAMATT5182	ADHESIVE STRIP	1
025	MAMATT5185	ADHESIVE STRIP	2
025	MAMATT5185	ADHESIVE STRIP	2

13. ACCESSORIES

CLOSED CABIN (4)



FIGURE	REFERENCE	DENOMINATION	AMOUNT
001	46.08611.01	BEACON	1
001	46.08611.01	BEACON	1
002	MATORNO486	SCREW	2
002	MATORNO486	SCREW	2
003	MATAPI1103	TRIMMING	1
003	MATAPI1103	TRIMMING	1
004	MACHAP9926	SHEET	1
004	MACHAP9926	SHEET	1
005	MACHAP10069	SHEET	2
006	MACHAP10060	SHEET	2
007	MACSOLO146	SUPPORT	2
008	MAARAN0008	WASHER	12
009	MATUER0011	NUT	12
010	MAIPLA0001	NUT	6
011	MACSOLO145	SUPPORT	4
012	MAARAN0050	WASHER	8
013	MATORN0149	SCREW	8
014	MACHAP9652	SHEET	1
015	MALIMP0274	WINDSCREEN WIPER ARM	1

019	MALIMP0275	WINDSCREEN WIPER	1
020	MACHAP10057	SHEET	1
021	MAIPLA0016	BULKHEAD	2
022	MACHAP10116	SHEET	4
023	MAARAN0080	WASHER	8
024	MATUER0005	NUT	8
025	MAIPLA0116	SHIM	25
026	MAARAN0060	WASHER	25
027	MATORN0488	SCREW	25

13. ACCESSORIES

CLOSED CABIN (5)



FIGURE	REFERENCE	DENOMINATION	AMOUNT
001	MAPERC0259	GASKET	2
002	MACHAP9919	SHEET	1
003	66.08223.00	GLASS	1
004	MACSOL0105	DASHBOARD PLATE	1
005	MACSOL0096	COVER	1
006	MAARAN0053	WASHER	6
007	MATORN0226	SCREW	6
008	MACHAP10114	SHEET	1
009	MACHAP10113	SHEET	1
010	MACHAP10115	SHEET	1
011	MAPERC0298	JOINT PROFILE	1
012	MAPERC0299	JOINT PROFILE	1
013	MATORN0273	SCREW	13
014	MATORN0210	SCREW	8
015	MACHAP10095	SHEET	1
016	MAARAN0008	WASHER	2
017	MAIPLA0218	KNOB	2
018	MATUER0005	NUT	11
019	MAIPLA0047	CAP	11

020	MATORN0177	SCREW	11
021	MACHAP10120	SUPPORT	1
022	MAPARA0008	SUN VISOR	1
023	MATORN0407	SCREW	2
024	MAIPLA0255	DOCUMENT HOLDER BOX	1
025	MATORN0416	SCREW	5
026	MAIPLA0016	BULKHEAD	2
027	MATT5183	ADHESIVE STRIP	1
028	MATT5184	ADHESIVE STRIP	1

13. ACCESSORIES

RADIO

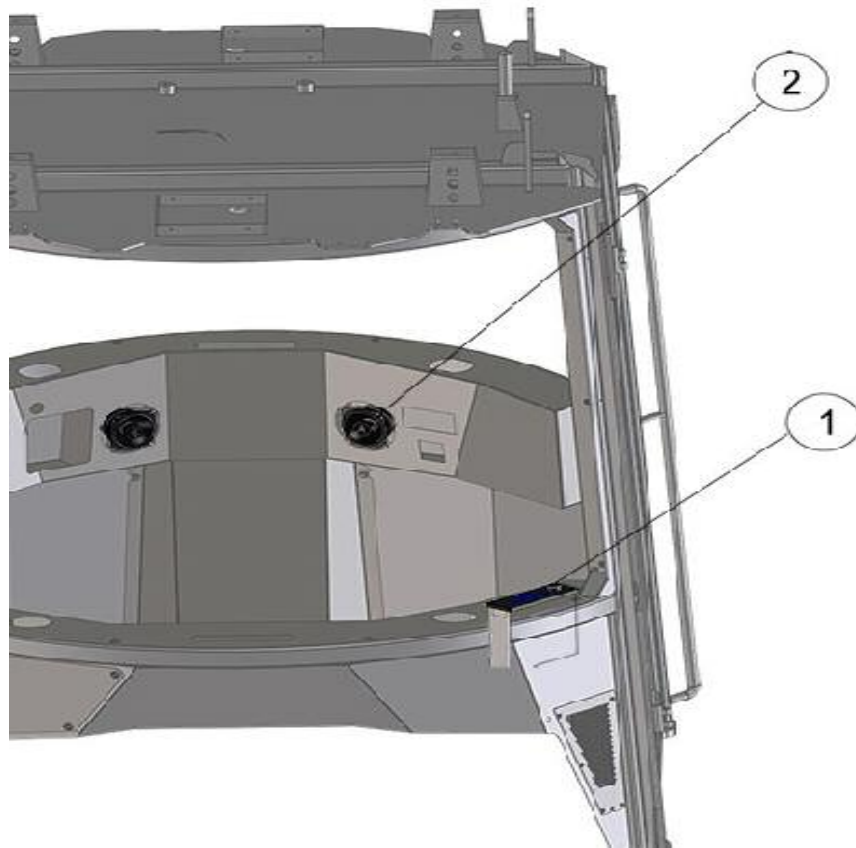

FIGURE	REFERENCE	DENOMINATION	AMOUNT
001	46.08798.02	RADIO + BLUETOOTH	1
002	57.13004.00	SPEAKER	2

13. ACCESSORIES

GERMANY CIRCULATION REGULATION (1)

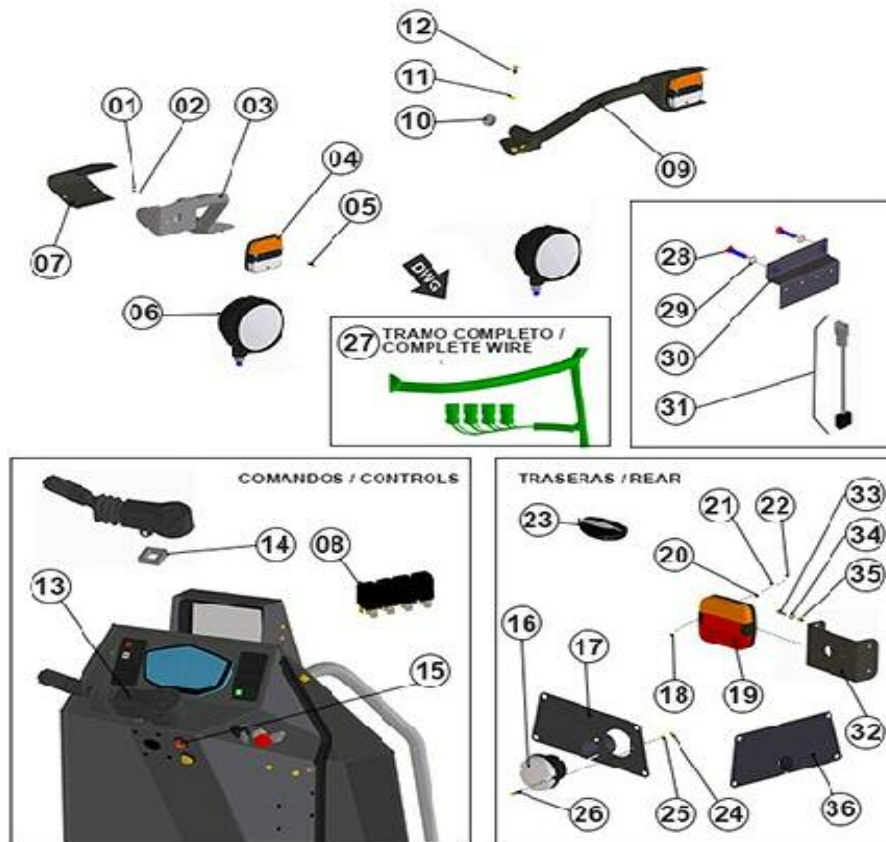

FIGURE	REFERENCE	DENOMINATION	AMOUNT
001	711.04000.66	NUT	4
002	101.04000.66	WASHER DIN125 D4	4
003	66.13001.00	HEADLIGHT SUPPORT RIGHT	1
004	66.11126.00	MULTIFUNCTION LED LIGHT	2
005	601.04020.87	SCREW DIN912 M4x20	4
006	66.11132.00	FRONTAL LIGHT LEFT AND RIGHT	2
007	66.13004.00	PROTECTOR LIGHT SUPPORT	2
008	IM.20026.03	MICRO RELAY WITH DIODE	4
009	66.13002.00	HEADLIGHT SUPPORT LEFT	1
010	02.32035.00	CAP	4
011	104.08000.00	WASHER DIN7980 D8	6
012	603.08020.86	SCREW DIN933 M8x20	6
013	70.11323.01	LIGHTS LEVER SWITCH	1
014	70.11025.00	ADHESIVE FOAM SEALER	1
015	66.11135.00	SWITCH WARNING LED	1
016	66.11127.00	LIGHT REVERSE LED	1

017	66.08014.00	SUPPORT REAR LIGHT AND SENSOR (9005)	1
018	601.04020.87	SCREW DIN912 M4x20	4

13. ACCESSORIES

GERMANY CIRCULATION REGULATION (1)

FIGURE	REFERENCE	DENOMINATION	AMOUNT
019	66.11125.00	MULTIFUNCTION LED LIGHT REAR	2
020	830.00606.00	BRIDA LAZO D6x6	2
021	101.04000.66	WASHER DIN125 D4	4
022	711.04000.66	NUT	4
023	66.11128.00	LED NUMBER PLATE	1
024	711.03000.67	nut Din985 M3	2
025	101.03000.67	WASHER DIN125 D3	2
026	601.03020.86	HEXAGON SOCKET HEAD SCREW DIN912 M3x20	2
027	66.11007.00	WIRE LIGHTS	1
028	603.06025.86	SCREW DIN933 M6x25	2
029	101.06000.66	WASHER DIN125 D6	2
030	66.11136.00	SUPPORT RESISTORS LED (9005)	1
031	66.11130.00	RESISTOR SMART LIGHT LED	1
032	66.08163.00	LIGHT SUPPORT	2
033	630.06025.96	SCREW ISO7380 M6x25	4
034	101.06000.66	WASHER DIN125 D6	4
035	711.06000.66	NUT DIN982 M6	4
036	66.08015.00	SENSOR SUPPORT RIGHT (9005)	1

13. ACCESSORIES

GERMANY CIRCULATION REGULATION (2)

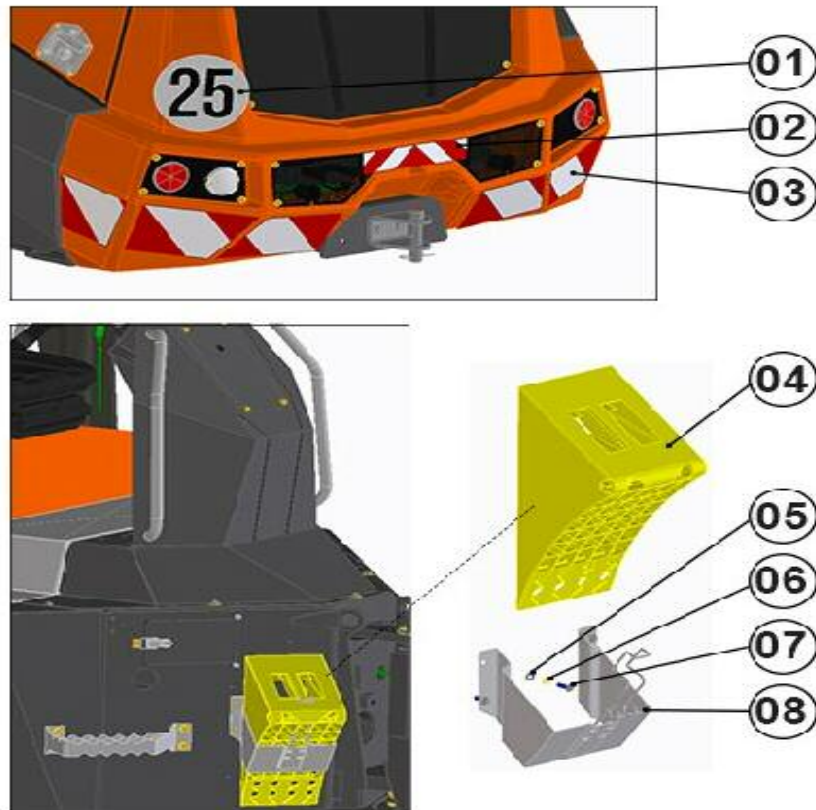

FIGURE	REFERENCE	DENOMINATION	AMOUNT
001	46.11720.00	STICKER 25KM/H	3
002	39.09901.00	PLATE AD. INDI	3
003	465.14017.00	REFLECTIVE STICKER 140MM	8
004	63.01420.00	WHEEL CHOCK 200X230X475	1
005	101.08000.66	WASHER DIN125 D8	4
006	104.08000.00	WASHER DIN7980 D8	4
007	630.08025.96	SCREW ISO7380	4
008	63.01421.00	SUPPORT WHEEL CHOCK 200X250X290	1

13. ACCESSORIES

SPARE PART WHEEL



FIGURE	REFERENCE	DENOMINATION	AMOUNT
001	63.07100DE03	RIGHT WHEEL	1
002	63.07103.02	RIM 16.00X22.5 OFFSET 0	1

13. ACCESSORIES

AUSTRIAN FINISHES (1)

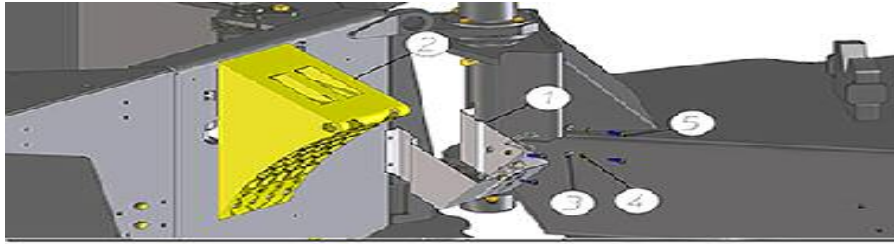

6



7



8



FIGURE	REFERENCE	DENOMINATION	AMOUNT
001	63.01421.00	SUPPORT WHEEL CHOCK 200X250X290	1
002	63.01420.00	WHEEL CHOCK 200X230X475	1
003	101.08000.66	WASHER DIN125 D8	4
004	104.08000.00	WASHER DIN7980 D8	4
005	630.08025.96	SCREW ISO7380	4
006	46.11720.00	STICKER 25KM/H	3
007	39.09901.00	PLATE AD. INDI	2
008	465.14017.00	REFLECTIVE STICKER 140MM	2

13. ACCESSORIES

AUSTRIAN FINISHES (2)

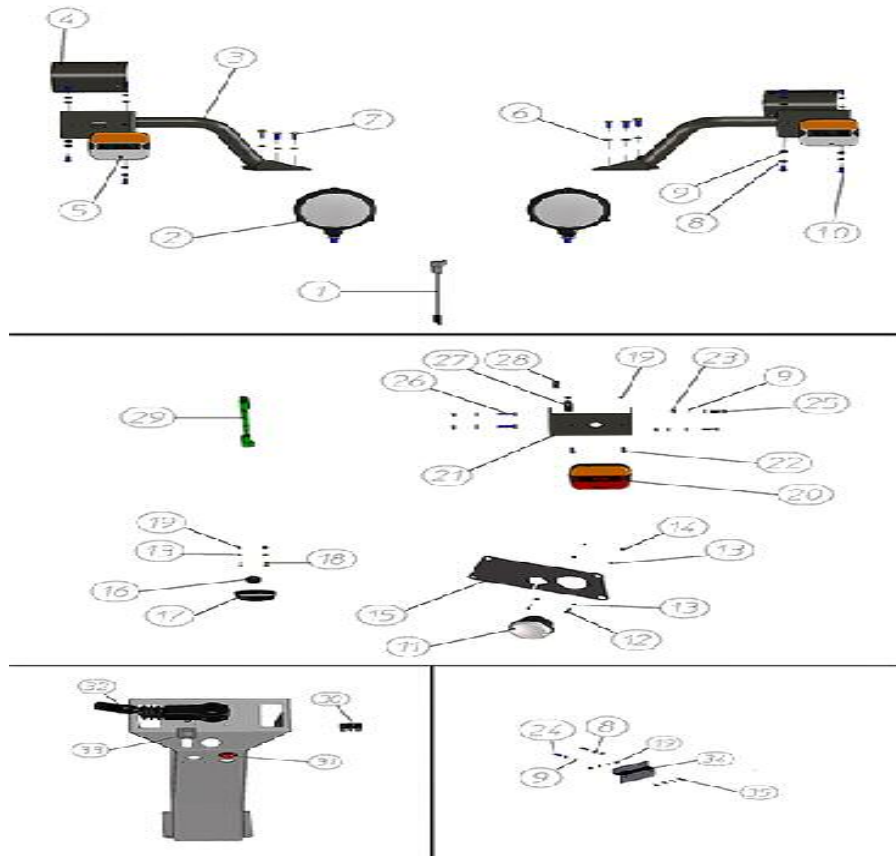

FIGURE	REFERENCE	DENOMINATION	AMOUNT
001	66.11130.00	RESISTOR SMART LIGHT LED	1
002	66.11132.00	FRONTAL LIGHT LEFT AND RIGHT	2
003	66.13001.00	HEADLIGHT SUPPORT RIGHT	2
004	66.13004.00	PROTECTOR LIGHT SUPPORT	2
005	66.11126.00	MULTIFUNCTION LED LIGHT	2
006	104.08000.00	WASHER DIN7980 D8	6
007	603.08020.86	SCREW DIN933 M8x20	6
008	104.06000.00	WASHER DIN7980 D6	8
009	101.06000.66	WASHER DIN125 D6	22
010	630.06015.96	SCREW ISO7380 M6x15	8
011	66.11127.00	LIGHT REVERSE LED	1
012	601.03020.86	HEXAGON SOCKET HEAD SCREW DIN912 M3x20	2
013	101.04000.66	WASHER DIN125 D4	14
014	711.03000.67	nut Din985 M3	2
015	66.08014.01	PLATE	1
016	16.00760.00	BUSH	1

017	66.11128.00	LED NUMBER PLATE	1
018	615.04020.66	SCREW DIN84	2

13. ACCESSORIES

AUSTRIAN FINISHES (2)

FIGURE	REFERENCE	DENOMINATION	AMOUNT
019	711.04000.66	NUT	14
020	66.11125.00	MULTIFUNCTION LED LIGHT REAR	2
021	66.08163.00	LIGHT SUPPORT	2
022	601.04020.87	SCREW DIN912 M4x20	4
023	711.06000.66	NUT DIN982 M6	8
024	630.06020.96	SCREW ISO7380 M6x20	2
025	630.06025.96	SCREW ISO7380 M6x25	4
026	603.06030.86	SCREW DIN933 M6x30	4
027	824.15000.00	CLAMP LOOP	2
028	43.07777.01	GROMMET 18X27X10	2
029	66.11020.00	CLEARANCE LIGHTS WIRING HARNESS	1
030	IM.20026.03	MICRO RELAY WITH DIODE	3
031	66.11135.00	SWITCH WARNING LED	1
032	70.11323.01	LIGHTS LEVER SWITCH	1
033	70.11025.00	ADHESIVE FOAM SEALER	1
034	66.11136.00	SUPPORT RESISTORS LED (9005)	1
035	615.04012.66	SCREW M4x12 DIN84	4

12. FINISHES

FINISHED FRANCE



FIGURE	REFERENCE	DENOMINATION	AMOUNT
001	14.00775.02	PLATE AD. INDI	2
002	02.00773.02	PLATE AD. INDI	1
003	02.00778.00	PLATE AD. INDI	1
004	02.00764.01	PLATE AD. INDI	1
005	02.00766.02	ADHESIVE 40X80 FRENCH	1

13. ACCESSORIES

LIGHTS

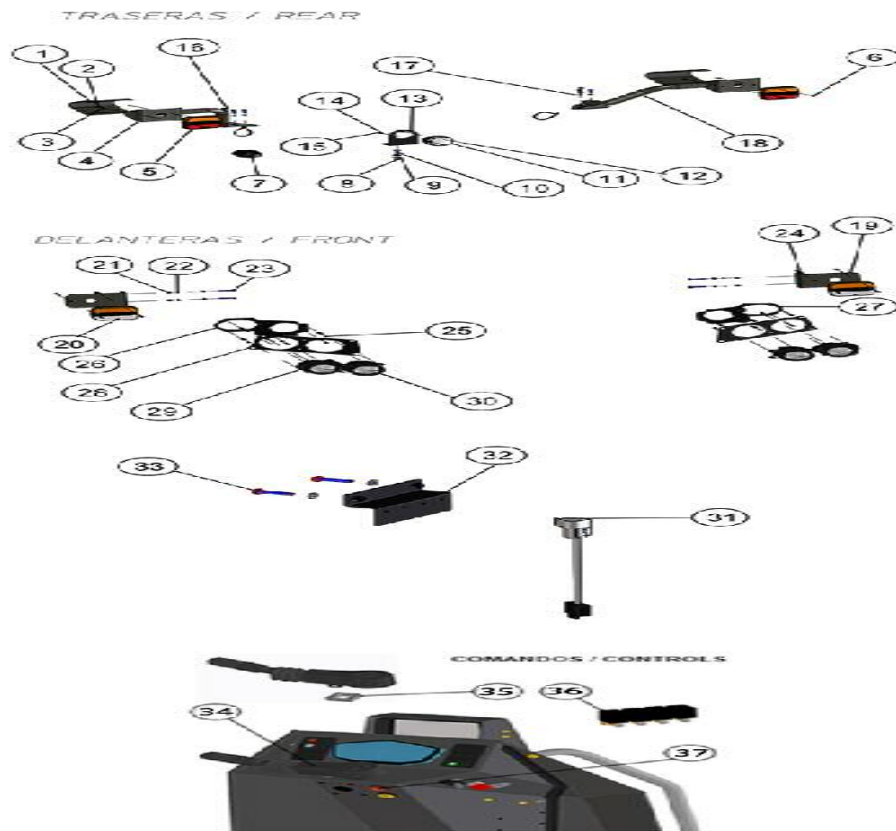

FIGURE	REFERENCE	DENOMINATION	AMOUNT
001	66.13004.00	PROTECTOR LIGHT SUPPORT	2
002	711.04000.66	NUT	26
003	101.04000.66	WASHER DIN125 D4	42
004	66.13001.00	HEADLIGHT SUPPORT RIGHT	1
005	66.11125.00	MULTIFUNCTION LED LIGHT REAR	2
006	601.04020.87	SCREW DIN912 M4x20	8
007	66.11128.00	LED NUMBER PLATE	1
008	711.10000.66	SHOCK ABSORBER	1
009	101.10000.66	WASHER DIN125 D10	2
010	603.10030.86	SCREW DIN933	1
011	66.11127.00	LIGHT REVERSE LED	1
012	601.03020.86	HEXAGON SOCKET HEAD SCREW DIN912 M3x20	2
013	66.04138.00	SHEET	1
014	101.03000.67	WASHER DIN125 D3	2
015	711.03000.67	nut Din985 M3	2
016	603.08020.86	SCREW DIN933 M8x20	6

017	104.08000.00	WASHER DIN7980 D8	6
018	66.13002.00	HEADLIGHT SUPPORT LEFT	1

13. ACCESSORIES

LIGHTS

FIGURE	REFERENCE	DENOMINATION	AMOUNT
019	66.08161.00	FIXING SUPPORT	2
020	66.11126.00	MULTIFUNCTION LED LIGHT	2
021	711.06000.66	NUT DIN982 M6	4
022	101.06000.66	WASHER DIN125 D6	10
023	603.06030.86	SCREW DIN933 M6x30	4
024	824.15000.00	CLAMP LOOP	2
025	601.04025.87	SCREW DIN 912 M4x25	16
026	66.08017.00	SHEET	1
027	66.08016.00	SHEET	1
028	66.08009.00	SHEET	2
029	46.11202.00	SHORT LIGHTS	2
030	46.11201.00	DRIVING LIGHT	2
031	66.11130.00	RESISTOR SMART LIGHT LED	4
032	66.11136.00	SUPPORT RESISTORS LED (9005)	1
033	603.06025.86	SCREW DIN933 M6x25	2
034	70.11323.01	LIGHTS LEVER SWITCH	1
035	70.11025.00	ADHESIVE FOAM SEALER	1
036	IM.20026.03	MICRO RELAY WITH DIODE	4
037	66.11135.00	SWITCH WARNING LED	1

13. ACCESSORIES

DUTCH FINISHES

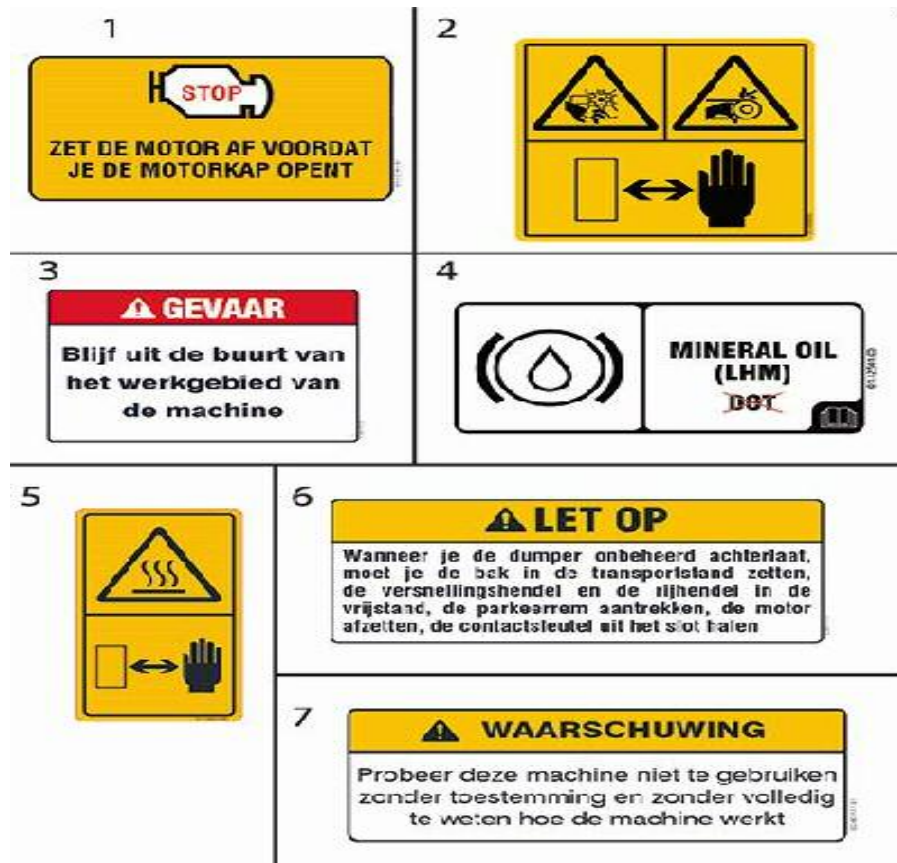

FIGURE	REFERENCE	DENOMINATION	AMOUNT
001	65.12104.31	SAFETY DECAL	2
002	01.12009.00		1
003	14.00775.31	SAFETY DECAL	2
004	01.12501.00	BRAKE ADHESIVE PLATE	1
005	01.12002.00		2
006	02.00773.31	SAFETY DECAL	1
007	02.00777.31	SAFETY DECAL	1

INDEX

02.ENGINE

01.ENGINE	2
03.INTAKE SYSTEM	3
04.MECHANICAL POWER	4
05.COOLING SYSTEM	6
	8

03. TRANSMISSION

Hydrostatic transmission	9
Hydrostatic engine	10
FRONT AXLE (1)	11
FRONT AXLE (2)	12
FRONT AXLE (3)	13
FRONT AXLE (4)	15
FRONT AXLE (5)	17
REAR AXLE (1)	18
REAR AXLE (2)	19
REAR AXLE (3)	20
REAR AXLE (4)	22
REAR AXLE (5)	24
Cardan Joint	25

04. CHASSIS

Chassis (Part 1)	26
Chassis (Part 2)	27
Chassis axle	28
SUPPORTS	29

05. BRAKING SYSTEM

01.FOOT BRAKE	30
---------------	----

05. ACTUATORS

BRAKES	31
ACCELERATOR	32

06. STEERING

Steering (Part 1)	33
Steering (Part 2)	34

RUEDAS

WHEELS	35
WHEELS - 89786	36

08. BODYWORK

SHEETS (1)	37
SHEETS (2)	39
SHEETS (3)	41
LOAD PROTECTOR	43
ROPS arch	44
SEAT	46
COUNTERWEIGHT	47
Joystick lever	48

09. MACHINE FUNCTIONS IMPLEMENTS

HOPPER	49
Rotating hopper support	50

10. HYDRAULIC INSTALLATION

PUMPS	52
Distributor	53
Valves	54
TANK	55
Oil tank	57
STANDARD HYDRAULIC DIAGRAM	58
STANDARD HYDRAULIC DIAGRAM - 93853	62

11. ELECTRIC INSTALLATION

Acoustic warning	66
------------------	----

10. HYDRAULIC INSTALLATION

67

11. ELECTRIC INSTALLATION

BATTERY	68
ELECTRIC SENSORS	70
WIRING HARNESS (PART 1)	71
Engine wiring harness	72
DASHBOARD (1)	73
	75
DASHBOARD WIRING	76
12. FINISHES	
STANDARD STICKER (1)	77
STANDARD STICKER (2)	78
STANDARD STICKER (3)	79
Tools bag	80
13. ACCESSORIES	
CLOSED CABIN	81
CLOSED CABIN (1)	83
CLOSED CABIN (2)	85
CLOSED CABIN (3)	89
CLOSED CABIN (4)	91
CLOSED CABIN (5)	92
RADIO	93
GERMANY CIRCULATION REGULATION (1)	94
GERMANY CIRCULATION REGULATION (2)	96
SPARE PART WHEEL	97
AUSTRIAN FINISHES (1)	98
AUSTRIAN FINISHES (2)	99
12. FINISHES	
Finished France	101
13. ACCESSORIES	
LIGHTS	102
DUTCH FINISHES	104